

# CIRCUS TRIO

## #213 3

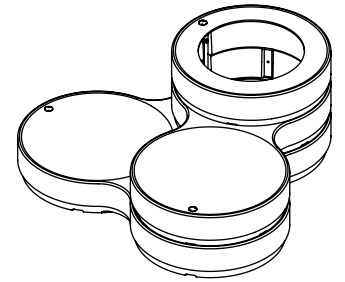
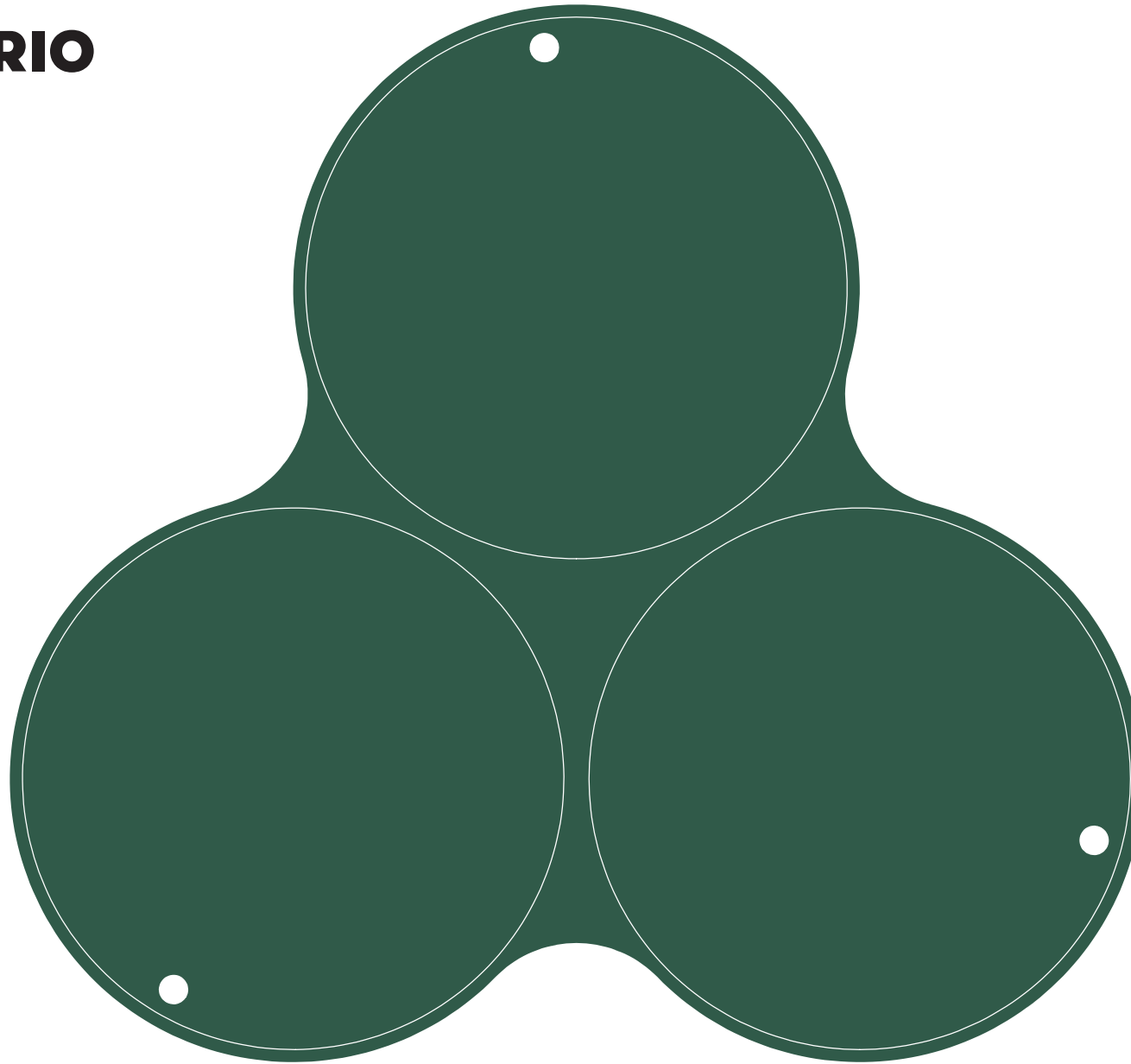

**GB**

DK/DE/ES/FR

**INDEX:**

**Item list.....**

Vareliste/ Artikelliste/ Lista de artículos/ Liste d'articles

**Preparing the bases.....**

Klargøring af baserne/Vorbereitung die basen/Preparación de las bases/Préparation les bases

**Connection Bracket B17.....**

Samlebeslag/Verbindungsbeschlag/Herraje de unión/Ferrure d'assemblage

**Connection Bracket B18.....**

Samlebeslag/Verbindungsbeschlag/Herraje de unión/Ferrure d'assemblage

**Filling.....**

Påfyldning/ Füllung/ Relleno/ Remplissage

**HPL/Wood Seat top Fixation.....**

Montering af sædetop/Befestigung der Sitzfläche/Fijación de la parte superior del asiento/Fixation de l'assise

**Planter / Seat & Planter top Fixation B21.....**

Beslag til plante top/ Pflanzküben-Deckel Befestigung/ Fijación de la parte superior de la jardinera/ Fixation du dessus du bac à plantes

**Ground Fixation B19.....**

Nedgravning/ Bodenbefestigung/ Fijación al suelo / Fixation au sol

**Surface Fixation B20.....**

Overflademontering/ Oberflächenmontage/ Superficie Montanosa/ Montage en saillie

**Shock Absorbing Surface and Impact Area.....**

Stødabsorberende overflade og stødområde/ Stoßabsorbierende Oberfläche und Aufprallbereich/ Superficie de absorción de impactos y área de impacto/Surface absorbant les chocs et zone d'impact

**Installation by Ground Recess.....**

Installation med terrænnedsænkning / Installation mit bodensenkung / Instalación con rebaje del terreno / Installation avec encastrément dans le sol

**PAGE**

01-02

03

03

04

05

05-07

07-09

10

10

11

12

**ITEM LIST**

ELEMENTLISTE/ARTIKELLISTE  
LISTA DE ARTICULOS/ LISTE DES ARTICLES

#213 81 xx BASE 1

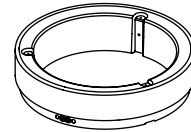

x1

#213 82 xx BASE 2

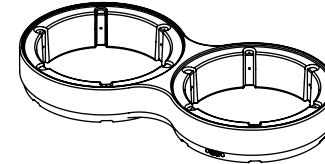

x1

#213 83 xx BASE 3

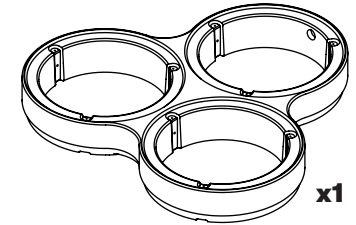

x1

#213 91 xx HPL Seat

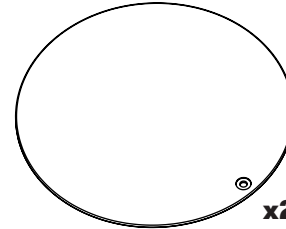

x2

#213 94 xx HPL Planter

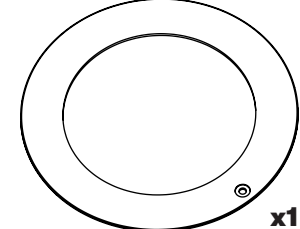

x1

ASSEMBLY KIT HPL SEAT

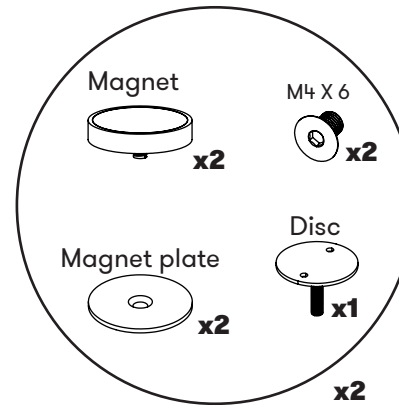

ASSEMBLY KIT HPL PLANTER TOP

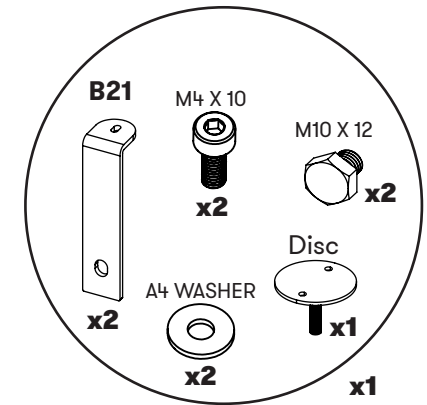

**ITEM LIST**

ELEMENTLISTE/ARTIKELLISTE  
LISTA DE ARTICULOS/ LISTE DES ARTICLES

**TRIO CONNECTION KIT**

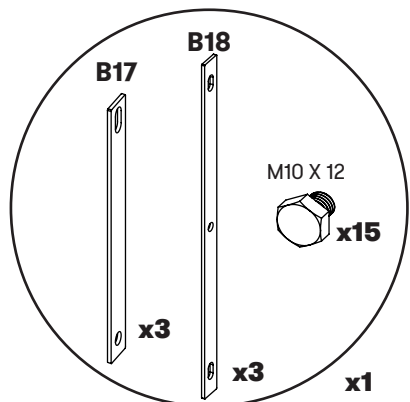

**TOOLS**

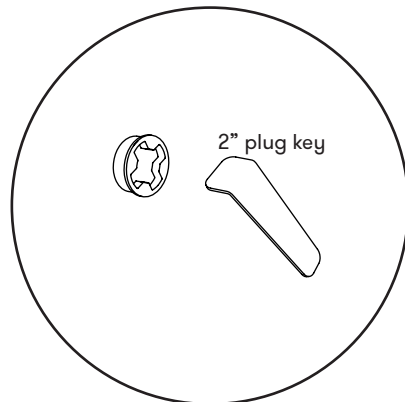

**TOOLS NEEDED NOT INCLUDED**

NØDVENDIGT VÆRKTØJ MEDFØLGER IKKE/BENØTIGTES WERKZEUG NICHT ENTHALTEN  
HERRAMIENTAS NECESARIAS NO INCLUIDAS/OUTILS NÉCESSAIRES NON INCLUS

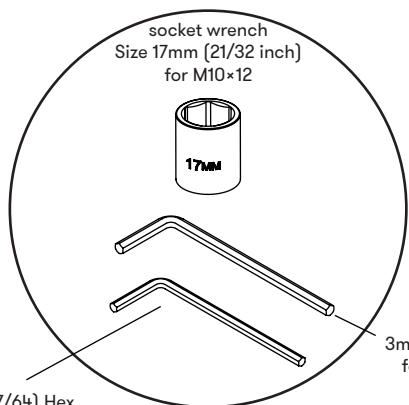
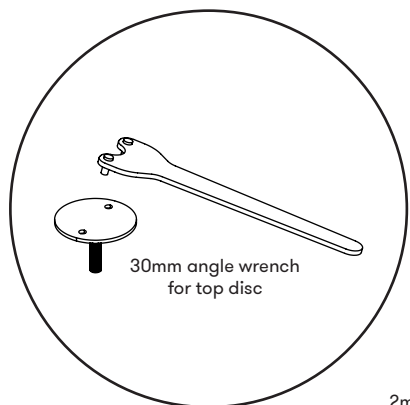

2mm (7/64) Hex key for magnet plate fixation

**OPTIONAL SELECTION**

TILVALG / OPTIONEN / OPCIONES / OPTIONS

**GROUND FIXATION**

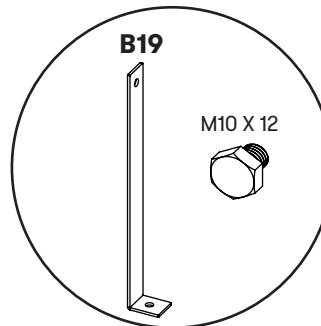

213 00 WOOD TOP

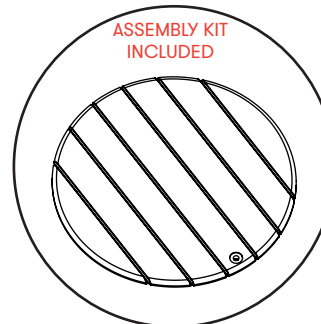

ASSEMBLY KIT WOOD TOP

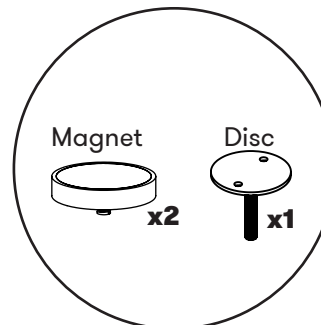

**SURFACE FIXATION**

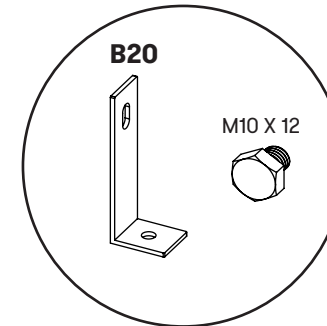

213 94 xx SEAT & PLANTER TOP

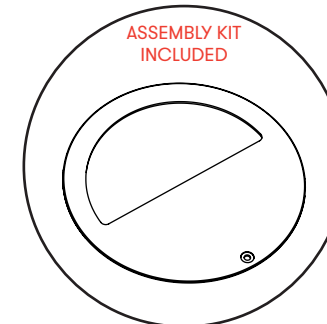

**CONCRETE BLOCK**

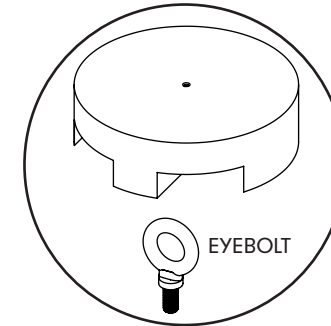

WHEELS & FEET

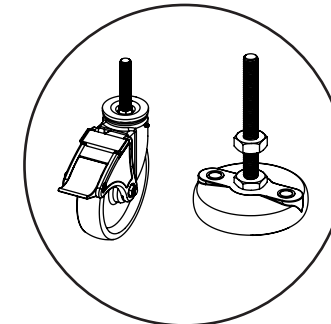

TRIO

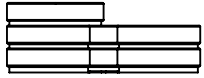
**PREPARING THE BASES**

KLARGØRING AF BASERNE/VORBEREITUNG DIE BASEN  
PREPARACIÓN DE LAS BASES/PRÉPARATION LES BASES

**1. STACK THE BASES**

STABLE DE BASER/STAPELN SIE DIE BASEN  
APILE LAS BASES/EMPILEZ LES BASES

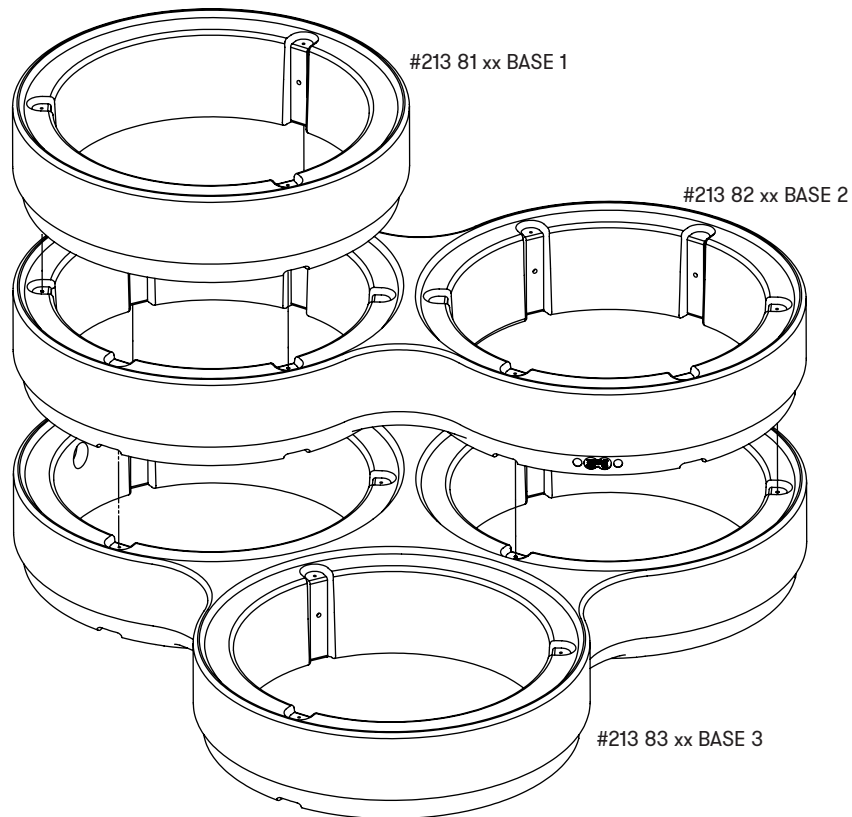
**2. ALIGN THE INSERTS**

TILPAS INDSATSERNE/RICHTEN SIE DIE EINSÄTZE AUS  
ALINEE LAS INSERCIONES/ALIGNEZ LES INSERTS

TRIO

**B17 - CONNECTION BRACKET**

SAMLEBESLAG / VERBINDUNGSBESCHLAG /  
HERRAJE DE UNIÓN / FERRURE D'ASSEMBLAGE

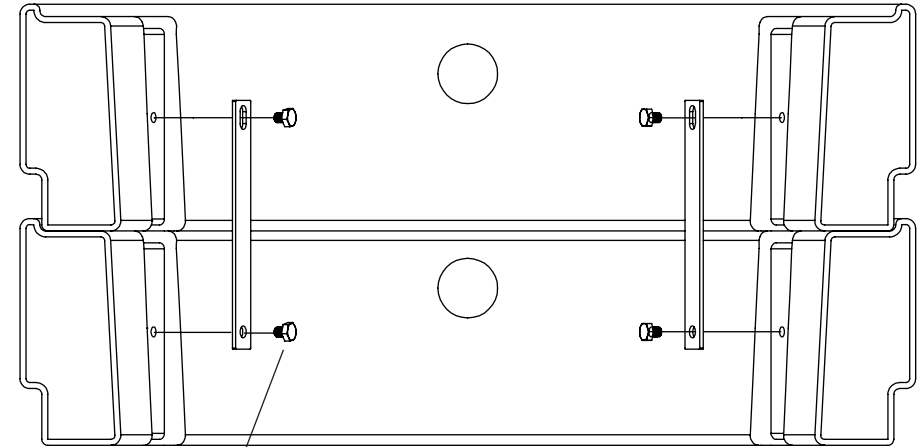

M10 X 12

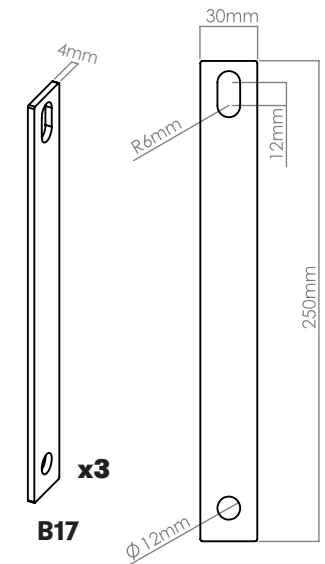

03

TRIO

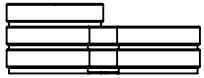

**B18 - CONNECTION BRACKET**  
 SAMLEBESLAG / VERBINDUNGSBESCHLAG /  
 HERRAJE DE UNIÓN / FERRURE D'ASSEMBLAGE

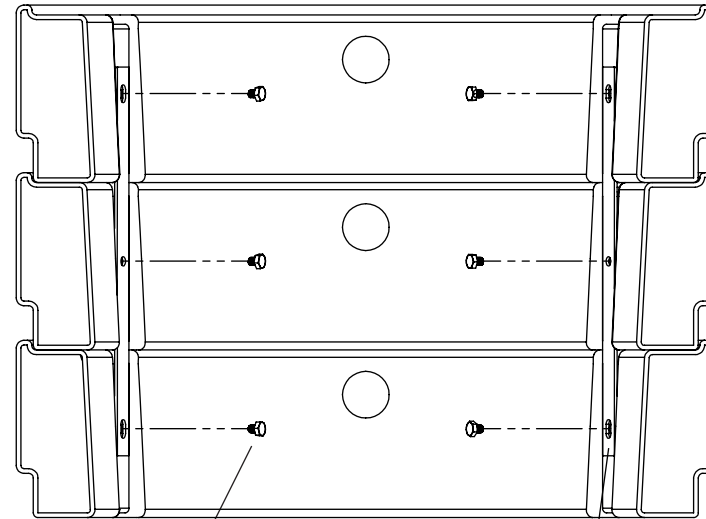
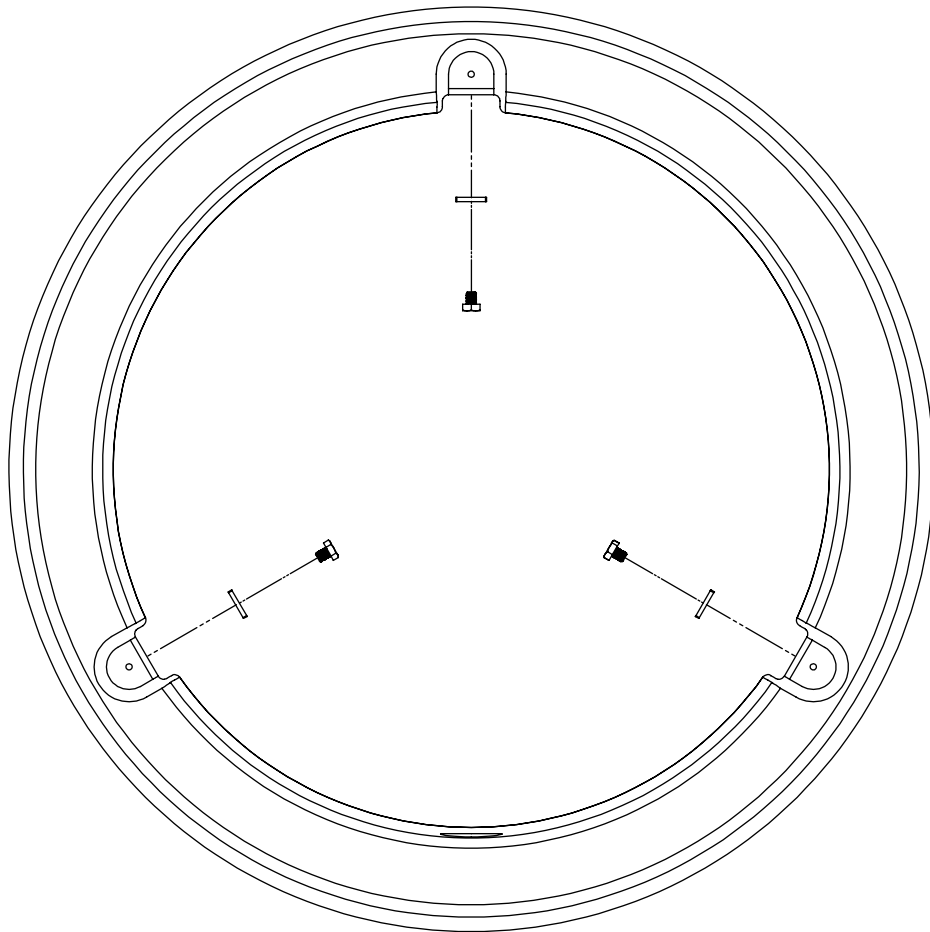

**x9**  
 M10 X 12

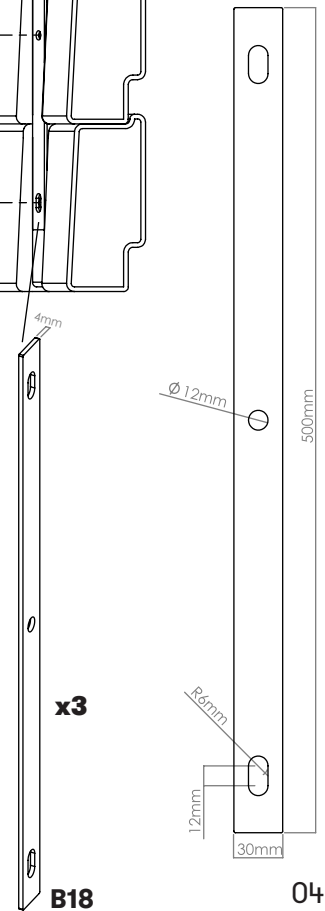

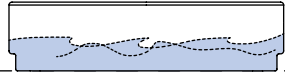

**WATER**  
VAND/WASSER/AGUA/EAU

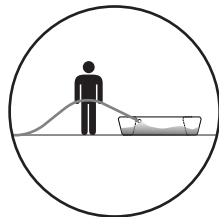
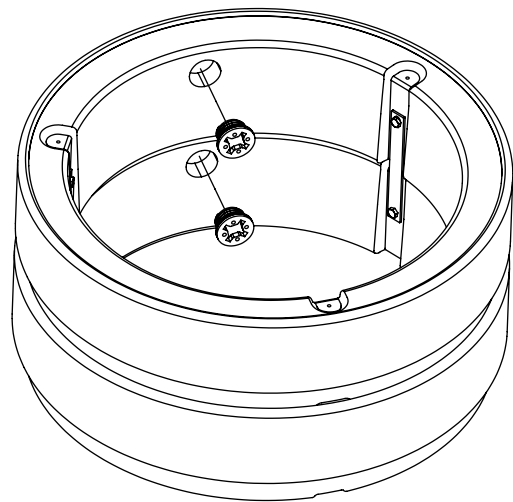
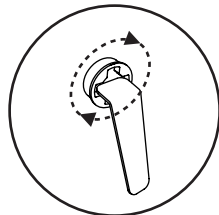
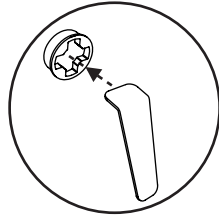
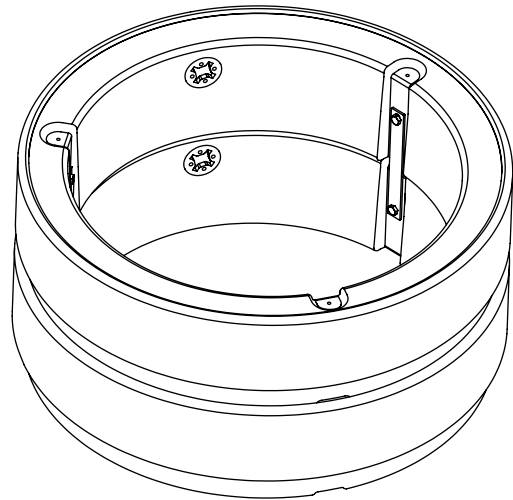

SOLO (16 kg)  
+ 60 L  
~ 76 kg

Measurements are excl top

TRIO



**HPL/WOOD SEAT TOP - FIXATION ASSEMBLY**  
MONTERING AF SÆDETOP/BEFESTIGUNG DER SITZFLÄCHE/  
FIJACIÓN DE LA PARTE SUPERIOR DEL ASIENTO/ FIXATION DE  
L'ASSISE

**1. MAGNET**  
IMÁN/AIMANT

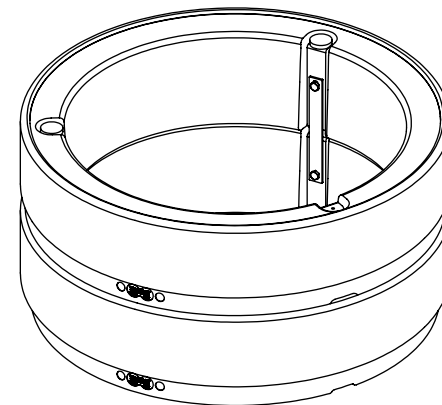
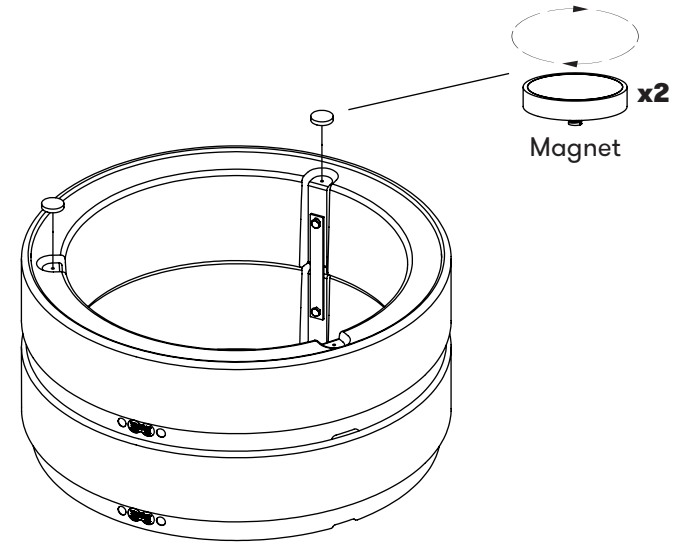

Measurements are excl top

out-sider a/s  
Kigkurren 8A, Islands Brygge  
DK-2300 Copenhagen S

info@out-sider.dk  
outsiderfurniture.com

TRIO

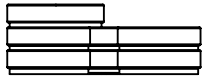

## 2. MAGNET PLATE ONLY FOR HPL TOP

MAGNETPLADE/MAGNETPLATTE/PLACA MAGNÉTICA/PLAQUE MAGNÉTIQUE

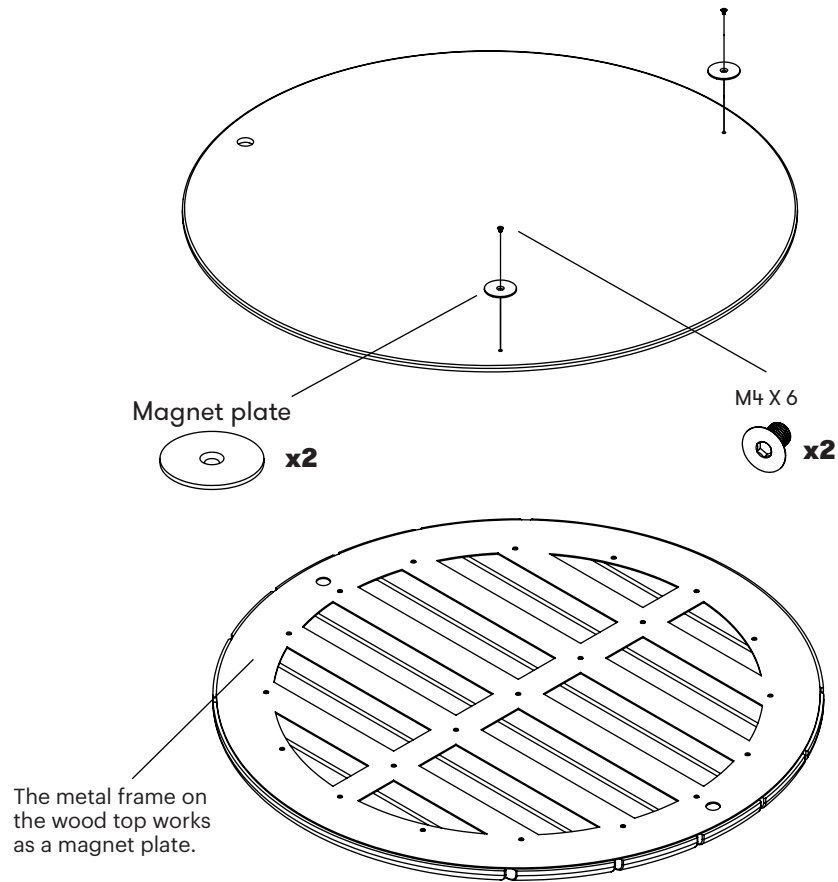

## 3. FITTING THE TOP

MONTERING AF TOPPEN/  
MONTAGE DES DECKELS/  
COLOCACIÓN DE LA TAPA/  
INSTALLATION DU DESSUS

1. Align the magnet plates on the top with the magnets in the base.
2. Gently lower the top connecting the magnets.

Make sure the insert in the base align with the hole in the top

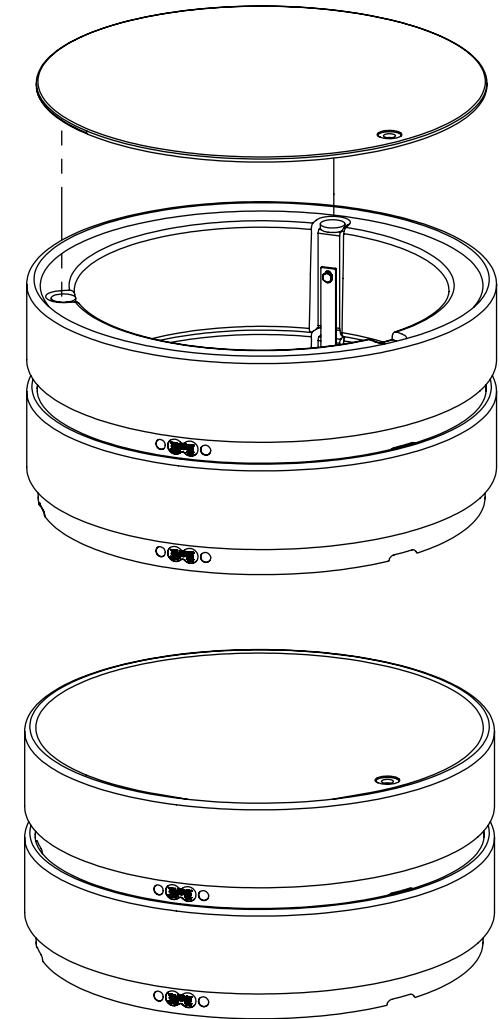

TRIO

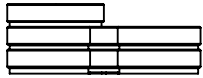

#### 4. TIGHTEN THE DISC

STRAM DISKEN/SCHEIBE ANZIEHEN  
APRIETE EL DISCO/SERREZ LE DISQUE

1. Place the disc in the top hole and tighten it with your hands.

Make sure to keep it vertical

2. Tighten the disc with the wrench spanner.

Do not over tighten

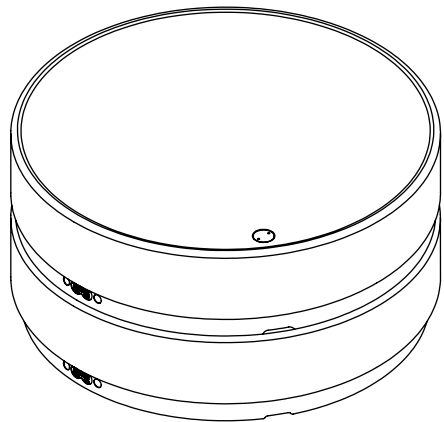
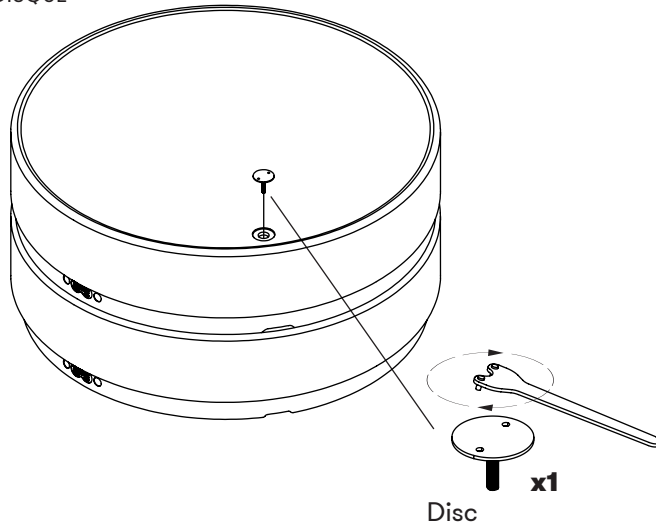

TRIO



#### B21 - PLANTER/SEAT & PLANTER TOP FIXATION

MONTERING AF PLANTE TOP/BEFESTIGUNG DES PFLANZKÜBEL-DECKELS/FIJACIÓN DE LA PARTE SUPERIOR DE LA JARDINERA/FIXATION DU DESSUS DU BAC Á PLANTES

#### 1A. BRACKET FIXATION

FASTGØRELSE AF BESLAG/HALTERUNGSBEFESTIGUNG/FIJACIÓN DEL SOPORTE/FIXATION DU SUPPORT

Place the top up-side down and fixate the B21 bracket with the M4X10 with the washer inbetween.

Make sure to protect the top surface when placing it up-side down

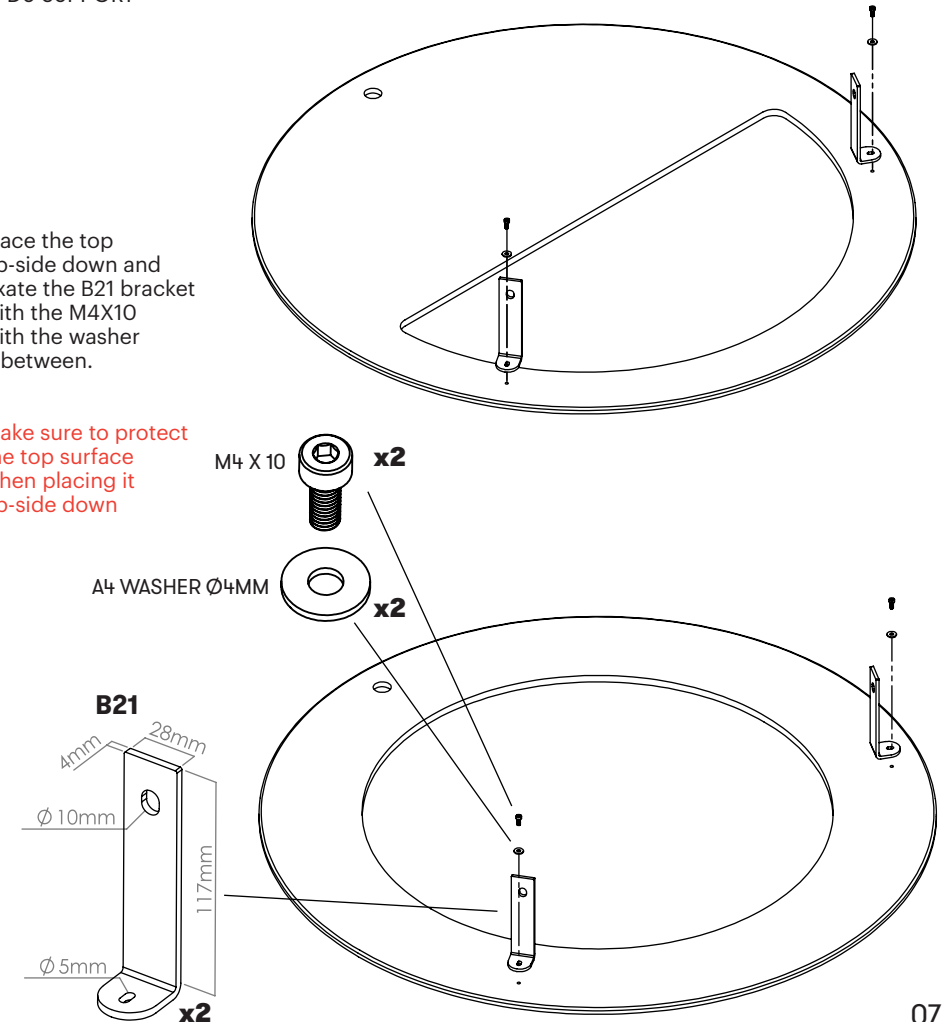

07

TRIO

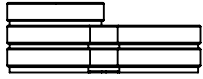
**1B. BRACKET FIXATION**

FASTGØRELSE AF BESLAG/HALTERUNGSBEFESTIGUNG/FIJACIÓN DEL SOPORTE/FIXATION  
DU SUPPORT

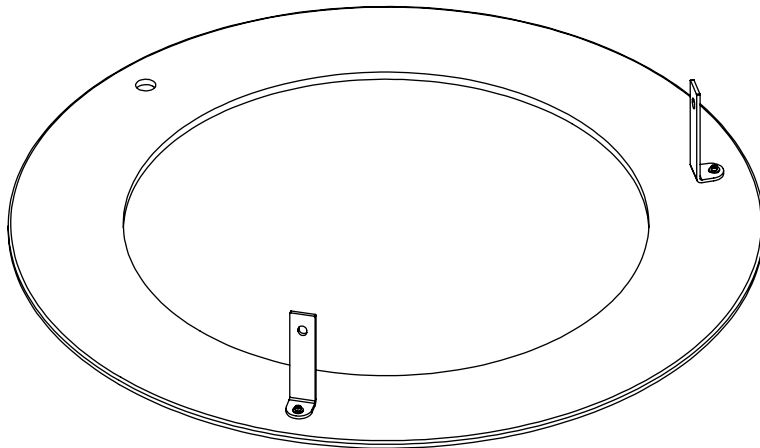
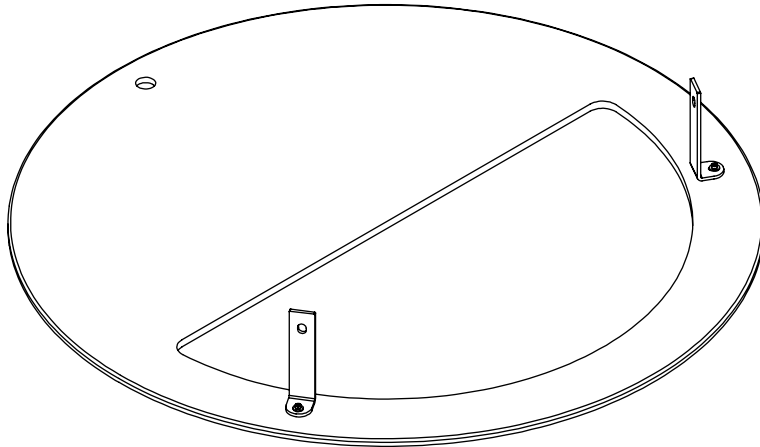
**2. PLACE THE TOP ON THE BASE**

PLACER TOPPEN PÅ BASEN/  
SETZEN SIE DEN DECKEL AUF DEN BODEN/  
COLOQUE LA TAPA SOBRE LA BASE/  
PLACEZ LE DESSUS SUR LA BASE

The B21 bracket can  
be fit on the inside  
and the outside of the  
connection brackets  
B17 and B18.

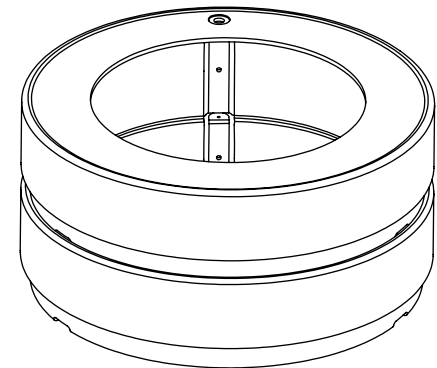
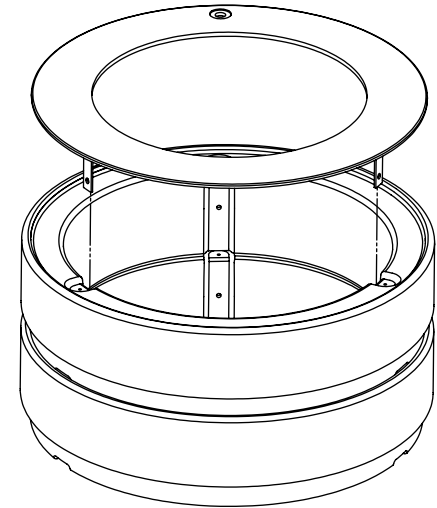

TRIO

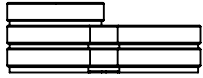
**3. BASE & TOP FIXATION**

FASTGØRELSE AF BASE & TOP/  
BEFESTIGUNG VON BODEN UND  
DECKEL/FIJACIÓN DE LA BASE Y LA  
PARTE SUPERIOR/FIXATION  
DE LA BASE ET DU DESSUS

Fixate the B21 bracket  
into the insert in the  
base with the M10x12

Keep in mind if your are  
using connection or/and  
ground/surface brackets  
to place them aligned so  
the connection bracket  
is fixated straight.

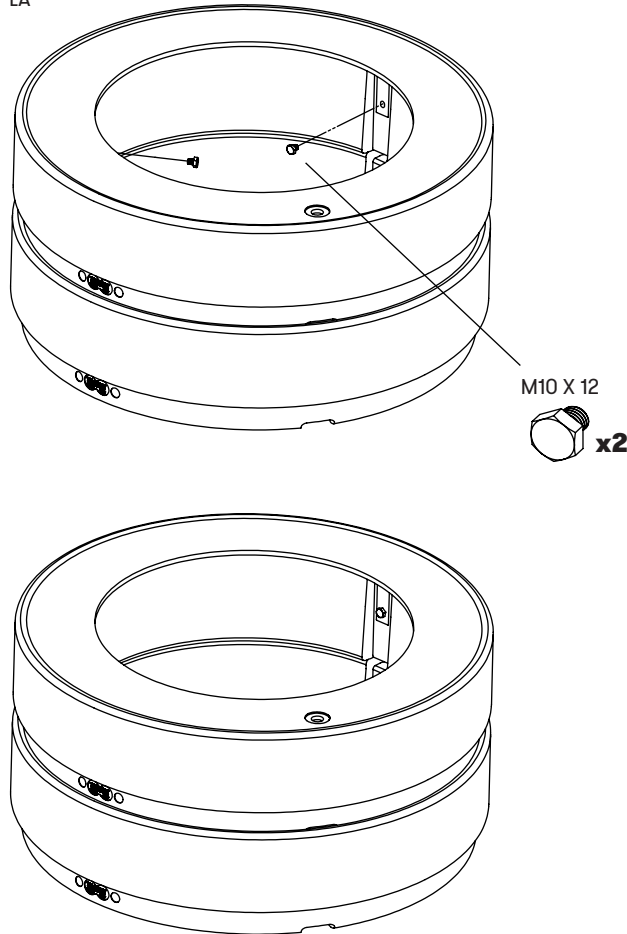
**4. TIGHTEN THE DISC**

STRAM DISKEN/SCHEIBE ANZIEHEN  
APRIETE EL DISCO/SERREZ LE DISQUE

1. Place the disc in the  
top hole and tighten it  
with your hands.

Make sure to keep it  
vertical

2. Tighten the disc with  
the wrench spanner.

Do not over overtighten

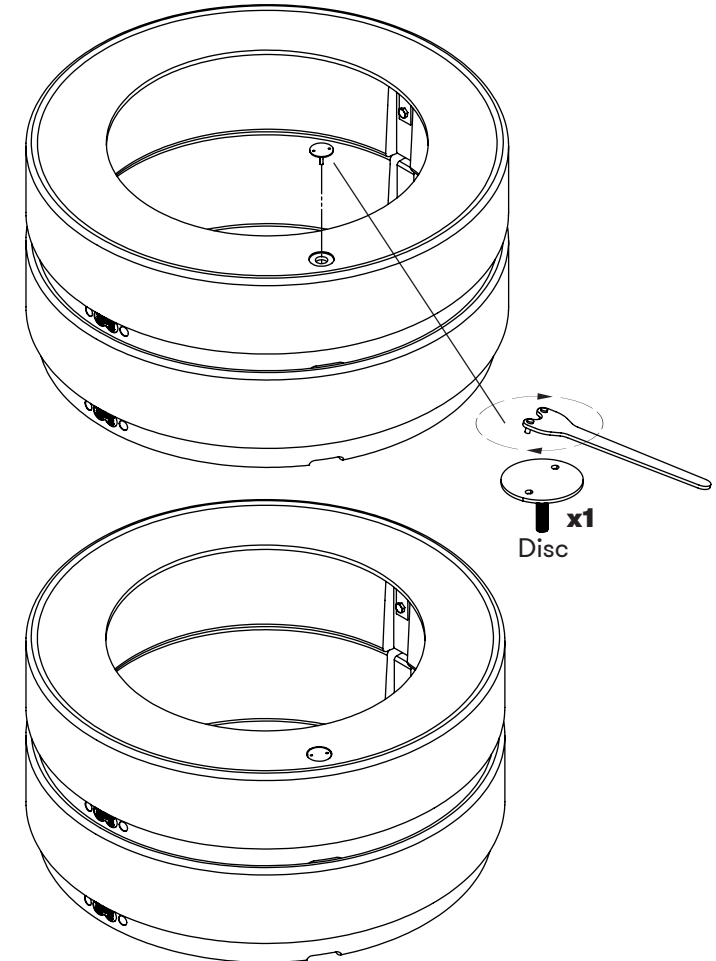

TRIO

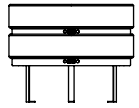

**B19 - GROUND FIXATION BRACKET**  
 NEDGRAVNING / BODENBEFESTIGUNG /  
 FIJACIÓN AL SUELO / FIXATION AU SOL

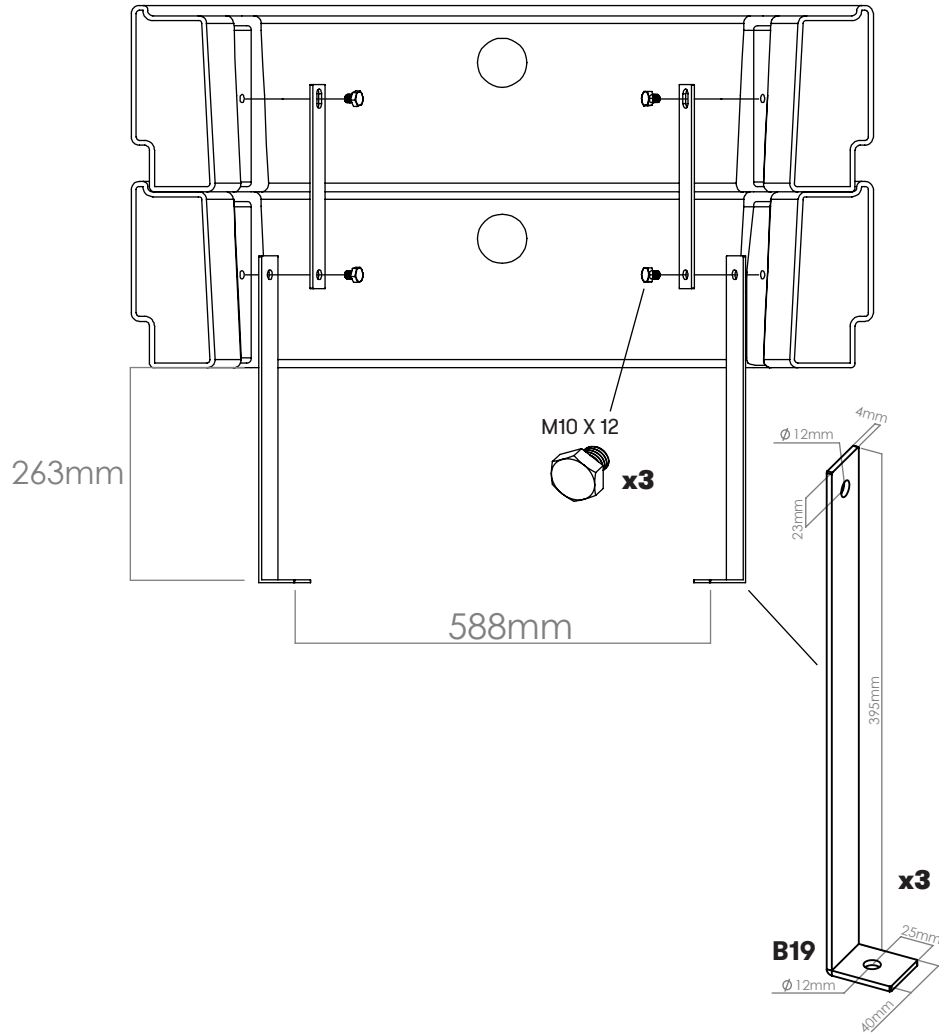

TRIO



**B20 - SURFACE FIXATION**  
 OVERFLADEMONTERING/OBERFLÄCHENMONTAGE/  
 SUPERFICIE MONTANOSA/MONTAGE EN SAILLIE

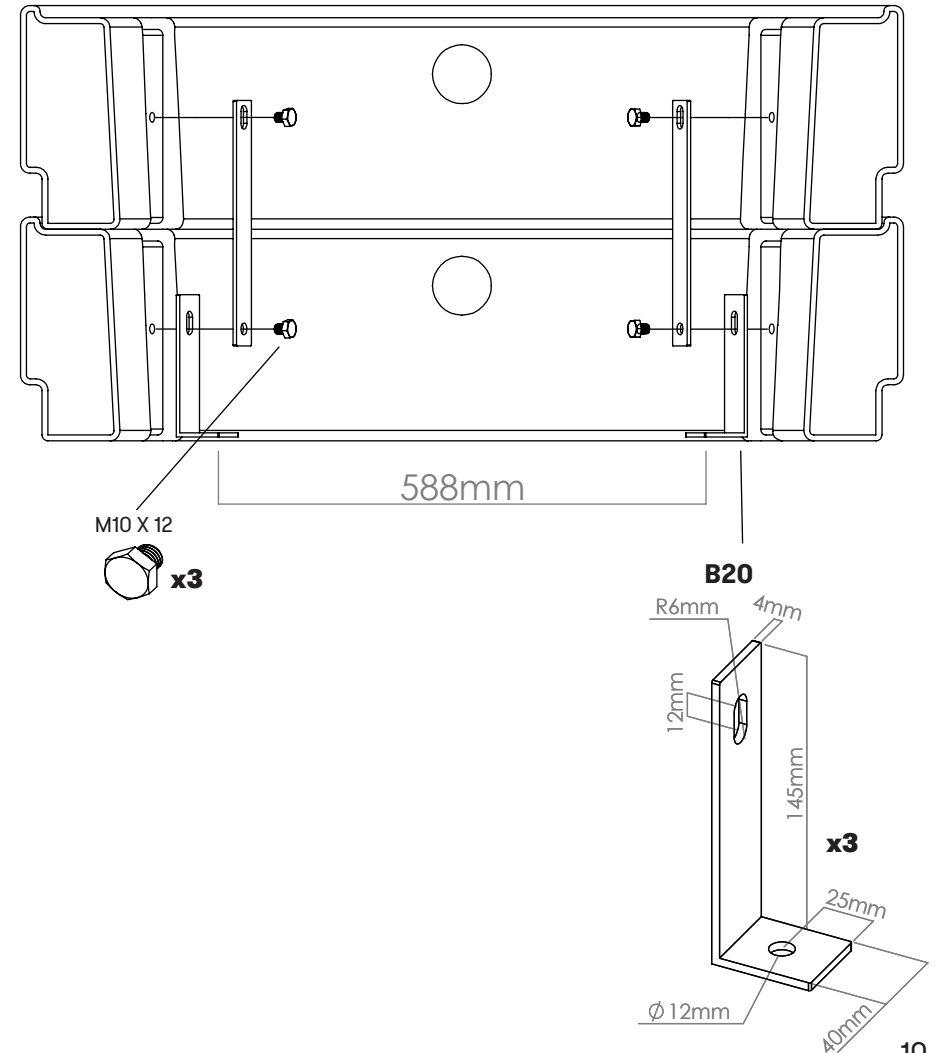

## SHOCK ABSORBING SURFACE AND IMPACT AREA

Stødabsorberende overflade og stødområde/  
 Stoßabsorbierende Oberfläche und Aufprallbereich/  
 Superficie de absorción de impactos y área de impacto/  
 Surface absorbant les chocs et zone d'impact

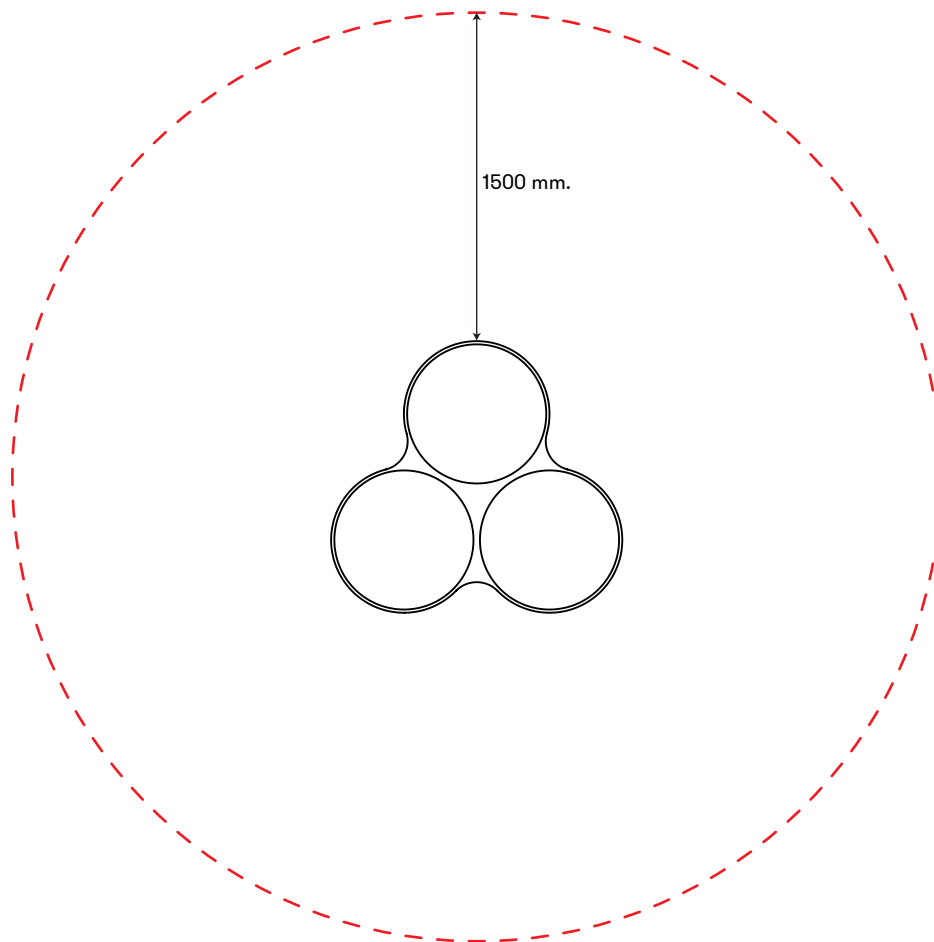

### GB

Shock absorbing surface and the extension of impact area.  
 In accordance with EN 1176-1:2023 we recommend an impact area of 1500mm  
 (see dotted line)

For equipment with a fall height (FH) >600mm, the max. FH for the impact absorbing surface material shall be documented.

**Note:** The max. FH for the Circus Trio is 660mm.

### DK

Stødabsorberende overflade og udvidelse af stødområdet.  
 I overensstemmelse med EN 1176-1:2023 anbefaler vi et stødområde på 1500 mm  
 (se stiplede linje)

For udstyr med en faldhøjde (FH) >600mm, må max. FH for virkningen absorberende overflademateriale skal dokumenteres.

**Bemærk:** Den max. FH for Circus Trio er 660 mm.

### DE

Stoßabsorbierende Oberfläche und Vergrößerung der Aufprallfläche.  
 Gemäß EN 1176-1:2023 empfehlen wir eine Aufprallfläche von 1500 mm  
 (siehe gestrichelte Linie)

Bei Geräten mit einer Fallhöhe (FH) >600mm beträgt die max. FH für die Wirkung absorbierendes Oberflächenmaterial ist zu dokumentieren.

**Hinweis:** Die max. FH für die Circus Trio beträgt 660 mm.

### ES

Superficie amortiguadora y extensión del área de impacto.  
 De acuerdo con EN 1176-1:2023 recomendamos un área de impacto de 1500 mm  
 (ver línea de puntos)

Para equipos con una altura de caída (FH) >600 mm, el máximo. FH por el impacto Se documentará el material de la superficie absorbente.

**Nota:** El máx. FH para el Circus Trio es de 660 mm.

### FR

Surface absorbant les chocs et extension de la zone d'impact.  
 Conformément à la norme EN 1176-1:2023, nous recommandons une zone d'impact de  
 1500 mm (voir ligne pointillée)

Pour les équipements avec une hauteur de chute (FH) >600 mm, la hauteur max. FH pour l'impact Le matériau de surface absorbant doit être documenté.

**Remarque :** Le maximum. FH pour le Circus Trio est de 660 mm.

## INSTALLATION BY GROUND RECESS

INSTALLATION MED TERRÆNNEDSÆNKNING / INSTALLATION MIT  
BODENVERSENKUNG / INSTALACIÓN CON REBAJE DEL TERRENO /  
INSTALLATION AVEC ENCASTREMENT DANS LE SOL

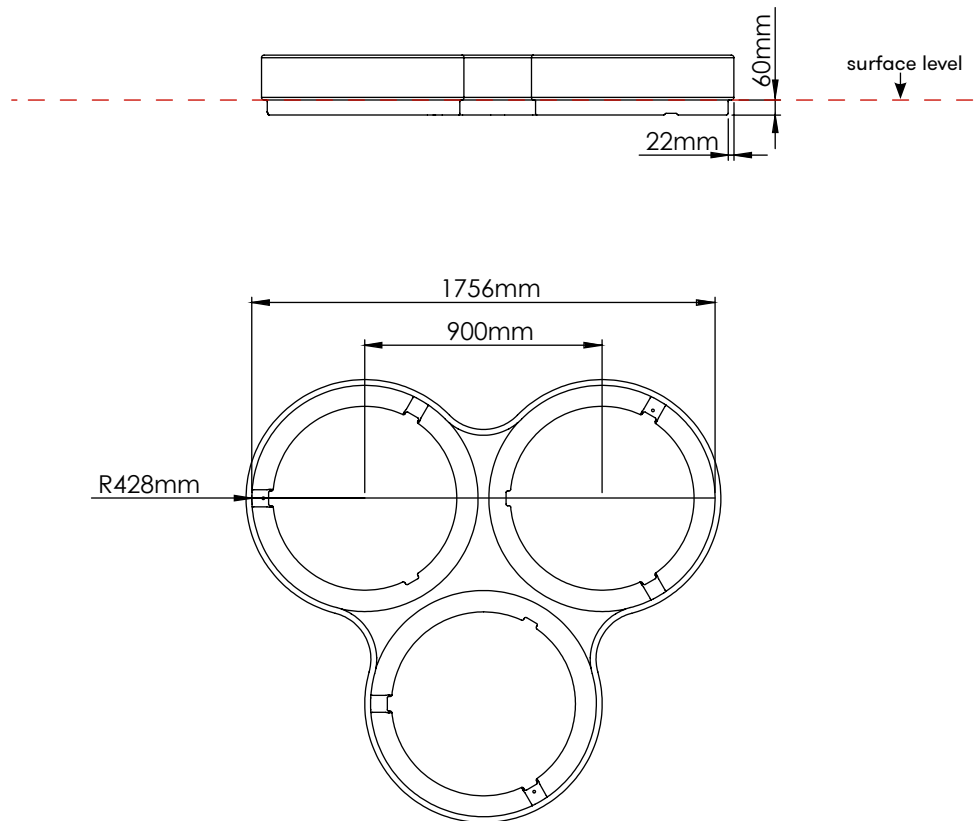

### GB

The Circus Trio can be installed with a 60 mm ground recess.

In accordance with EN 1176-1:2023, we recommend recessing the unit 60 mm below finished ground level. This reduces the maximum fall height to 600 mm.

When installed in this manner, no additional shock-absorbing surfacing or impact area is required.

**Note:** The maximum fall height of the Circus Trio is 660 mm when installed without ground recess.

### DK

Circus Trio kan installeres med 60 mm nedfældning i underlaget.

I overensstemmelse med EN 1176-1:2023 anbefaler vi, at enheden placeres 60 mm under det færdige niveau. Dette reducerer den maksimale faldhøjde til 600 mm.

Ved denne installation er der ikke krav om yderligere stødabsorberende overflade eller stødområde.

**Bemærk:** Den maksimale faldhøjde for Circus Trio er 660 mm ved installation uden nedfældning.

### DE

Das Circus Trio kann mit einer 60 mm Einbautiefe im Boden installiert werden.

Gemäß EN 1176-1:2023 empfehlen wir, das Gerät 60 mm unter dem fertigen Geländeniveau zu platzieren. Dadurch wird die maximale Fallhöhe auf 600 mm reduziert.

Bei dieser Installationsart ist keine zusätzliche stoßabsorbierende Oberfläche oder Aufprallfläche erforderlich.

**Hinweis:** Die maximale Fallhöhe des Circus Trio beträgt 660 mm bei Installation ohne Einbau im Boden.

### ES

El Circus Trio puede instalarse con una profundidad de empotramiento de 60 mm.

De acuerdo con la norma EN 1176-1:2023, recomendamos colocar la unidad 60 mm por debajo del nivel final del suelo. Esto reduce la altura máxima de caída a 600 mm.

Cuando se instala de esta manera, no se requiere superficie amortiguadora ni área de impacto adicional.

**Nota:** la altura máxima de caída del Circus Trio es de 660 mm cuando se instala sin empotramiento.

### FR

Le Circus Trio peut être installé avec un encastrément de 60 mm dans le sol.

Conformément à la norme EN 1176-1:2023, nous recommandons de placer l'unité 60 mm sous le niveau fini du sol. Cela réduit la hauteur de chute maximale à 600 mm.

Dans ce cas d'installation, aucune surface absorbant les chocs ni zone d'impact supplémentaire n'est requise.

**Remarque :** la hauteur de chute maximale du Circus Trio est de 660 mm lorsqu'il est installé sans encastrément.