

CIRCUS SOLO

#213 1

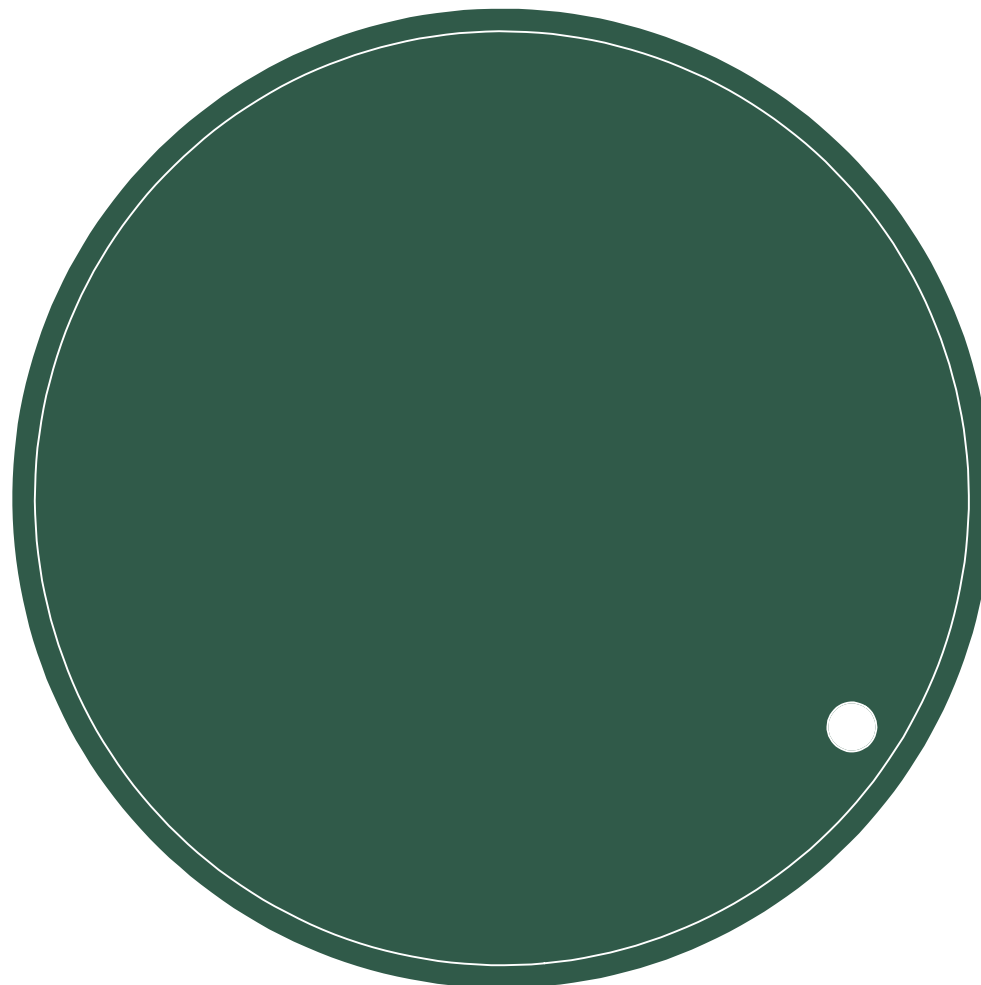
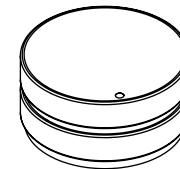

GB
DK/DE/ES/FR

INDEX:	PAGE
Item list Vareliste/ Artikelliste/ Lista de artículos/ Liste d'articles	01-02
Preparing the bases Klargøring af baserne/Vorbereitung die basen/Preparación de las bases/Préparation les bases	03
Connection Bracket B17 Samlebeslag/Verbindungsbeschlag/Herraje de unión/Ferrure d'assemblage	03
Filling Påfyldning/ Füllung/ Relleno/ Remplissage	04
HPL/Wood Seat top Fixation Montering af sædetop/Befestigung der Sitzfläche/Fijación de la parte superior del asiento/Fixation de l'assise	04-06
Ground Fixation B19 Nedgravning/ Bodenbefestigung/ Fijación al suelo / Fixation au sol	06
Surface Fixation B20 Overflademontering/ Oberflächenmontage/ Superficie Montanosa/ Montage en saillie	07
Planter / Seat & Planter top Fixation B21 Beslag til plante top/ Pflanzküben-Deckel Befestigung/ Fijación de la parte superior de la jardinera/ Fixation du dessus du bac á plantes	07-09
Shock Absorbing Surface and Impact Area Stødabsorberende overflade og stødområde/ Stoßabsorbierende Oberfläche und Aufprallbereich/ Superficie de absorción de impactos y área de impacto/Surface absorbant les chocs et zone d'impact	10

ITEM LIST
ELEMENTLISTE/ARTIKELLISTE
LISTA DE ARTICULOS/ LISTE DES ARTICLES

#213 81 xx BASE 1

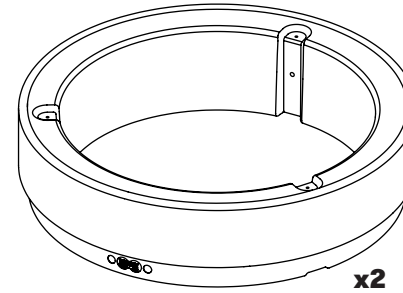

#213 91 xx HPL SEAT

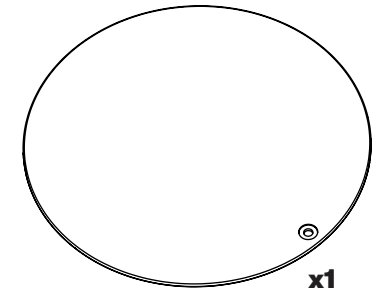

SOLO CONNECTION KIT

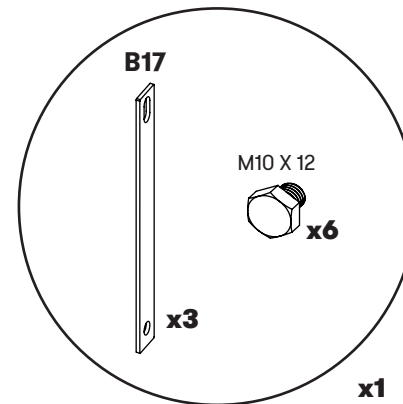

ASSEMBLY KIT HPL SEAT

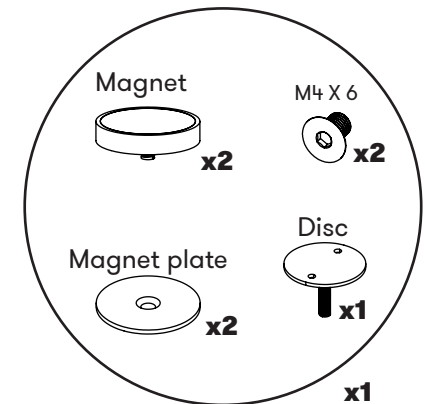

ITEM LIST

ELEMENTLISTE/ARTIKELLISTE
LISTA DE ARTICULOS/ LISTE DES ARTICLES

TOOLS

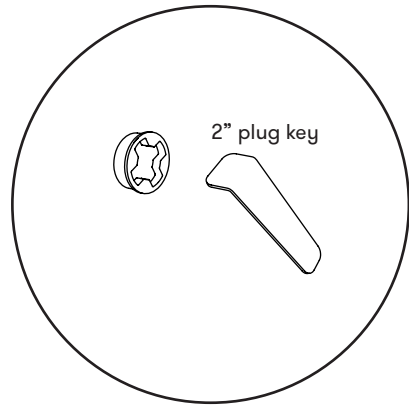

TOOLS NEEDED NOT INCLUDED

NØDVENDIGT VÆRKTØJ MEDFØLGER IKKE/BENØTIGTES WERKZEUG NICHT ENTHALTEN
HERRAMIENTAS NECESARIAS NO INCLUIDAS/OUTILS NÉCESSAIRES NON INCLUS

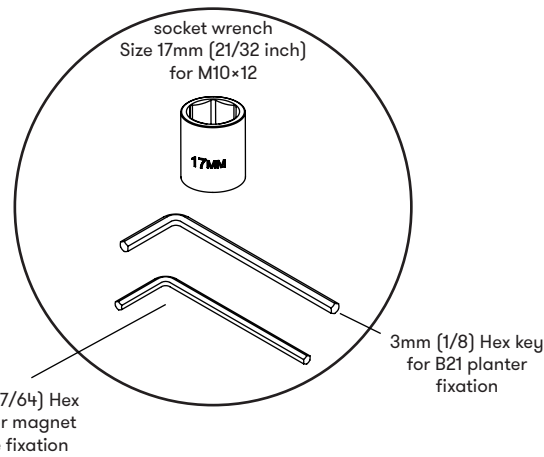
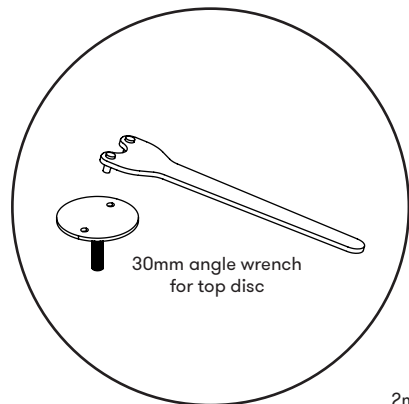

OPTIONAL SELECTION

TILVALG / OPTIONEN / OPCIONES / OPTIONS

GROUND FIXATION

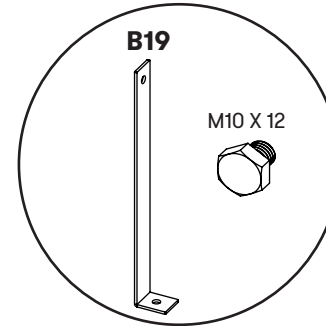

213 00 WOOD TOP

SURFACE FIXATION

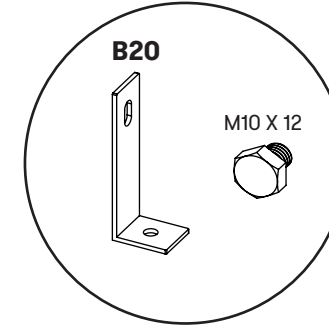

213 93 xx PLANTER TOP

CONCRETE BLOCK

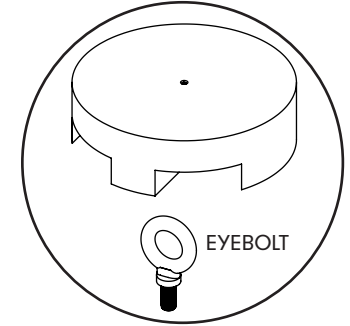

213 94 xx SEAT & PLANTER TOP

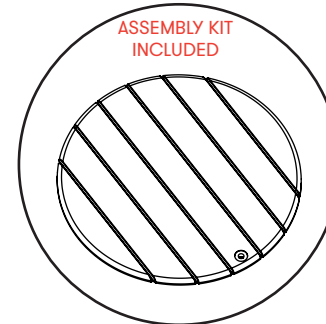

ASSEMBLY KIT WOOD TOP

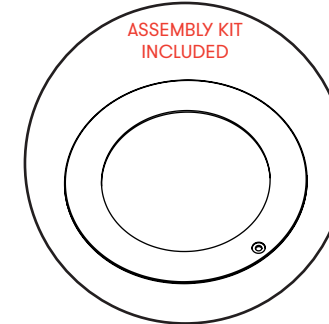

ASSEMBLY KIT HPL PLANTER TOP

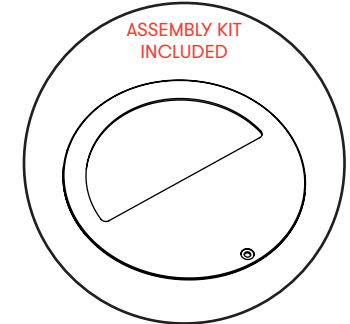

WHEELS & FEET

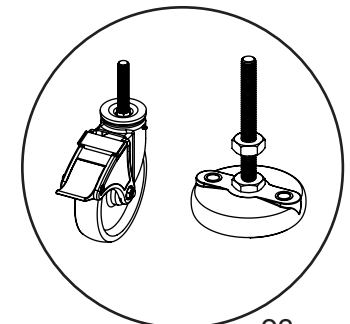
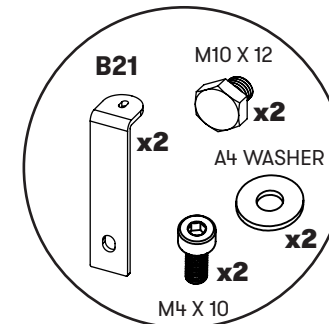
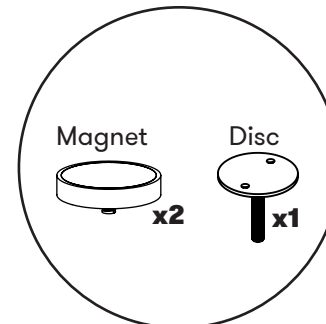

SOLO

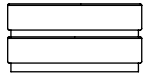
**PREPARING THE BASES**

KLARGØRING AF BASERNE/VORBEREITUNG DIE BASEN
PREPARACIÓN DE LAS BASES/PRÉPARATION LES BASES

1. STACK THE TWO BASES

STABLE DE TO BASER/STAPELN SIE DIE BEIDEN BASEN
APILE LAS DOS BASES/EMPILEZ LES DEUX BASES

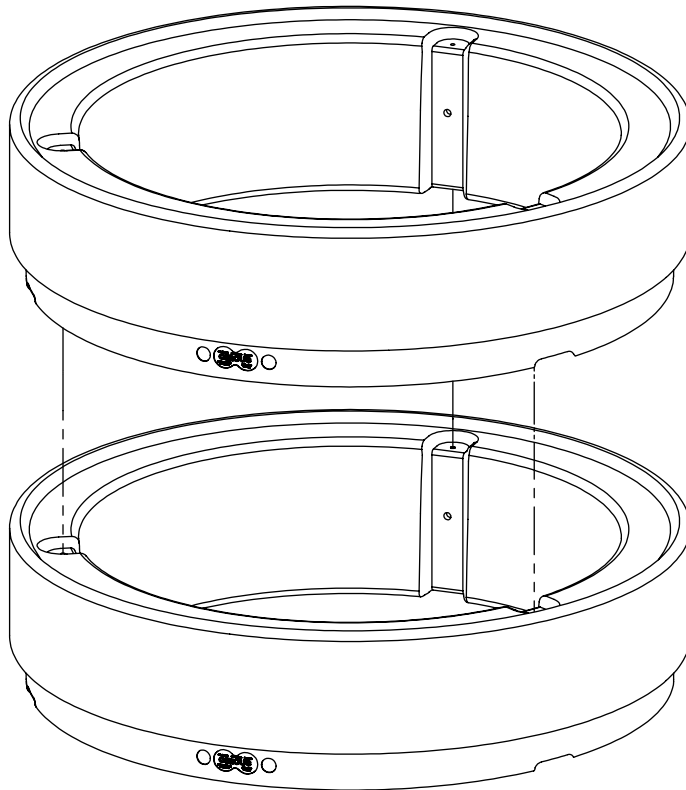
**2. ALIGN THE INSERTS**

TILPAS INDSATSERNE/RICHTEN SIE DIE EINSÄTZE AUS
ALINEE LAS INSERCIONES/ALIGNEZ LES INSERTS

SOLO

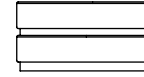
**B17 - CONNECTION BRACKET**

SAMLEBESLAG / VERBINDUNGSBESCHLAG /
HERRAJE DE UNIÓN / FERRURE D'ASSEMBLAGE

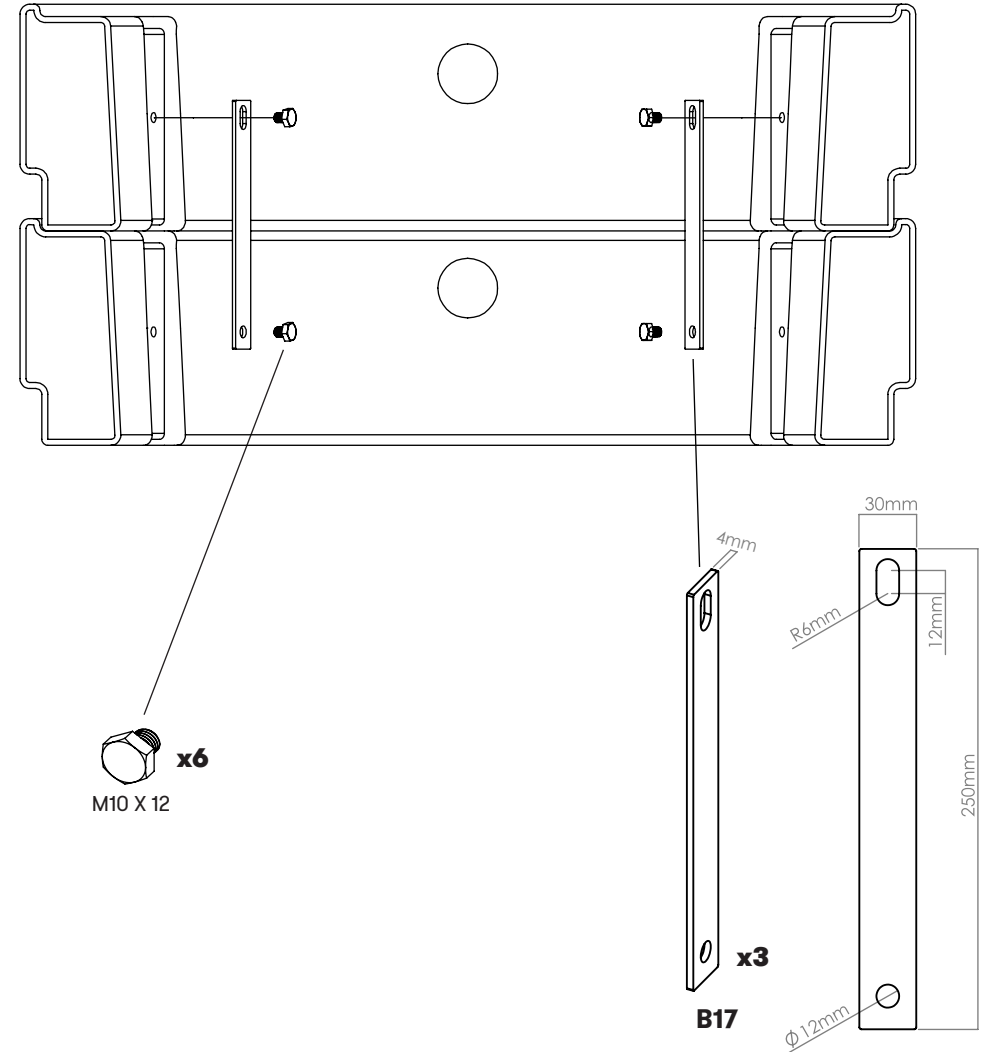

03

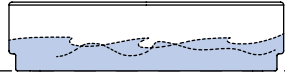

WATER
VAND/WASSER/AGUA/EAU

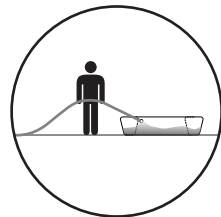
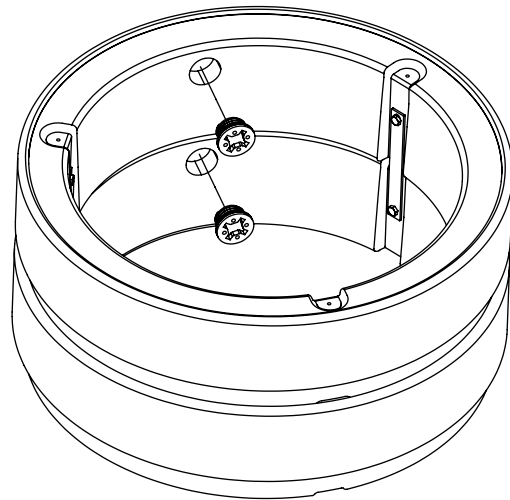
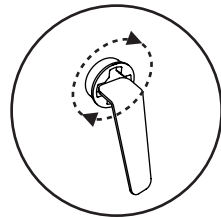
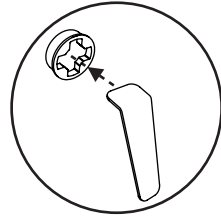
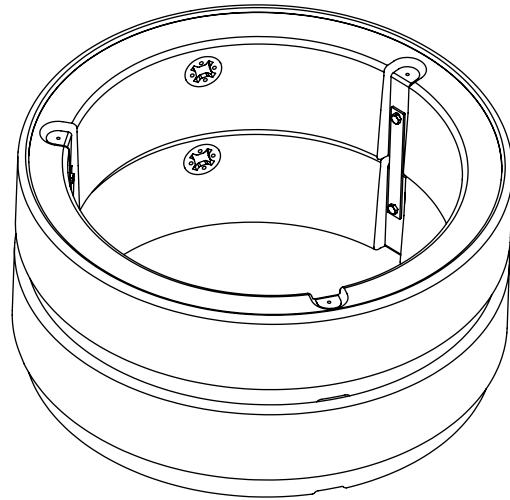

SOLO (16 kg)
+ 60 L
~ 76 kg

Measurements are excl top

SOLO

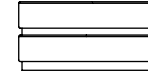

HPL/WOOD SEAT TOP - FIXATION ASSEMBLY
MONTERING AF SÆDETOP/BEFESTIGUNG DER SITZFLÄCHE/
FIJACIÓN DE LA PARTE SUPERIOR DEL ASIENTO/ FIXATION DE
L'ASSISE

1. MAGNET
IMÁN/AIMANT

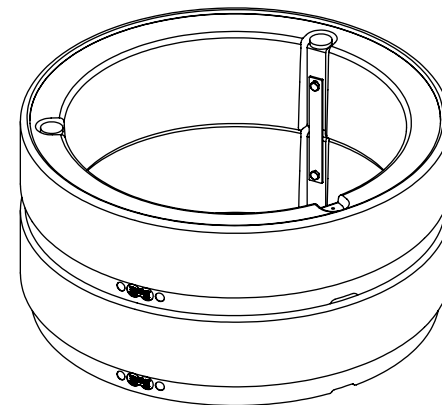
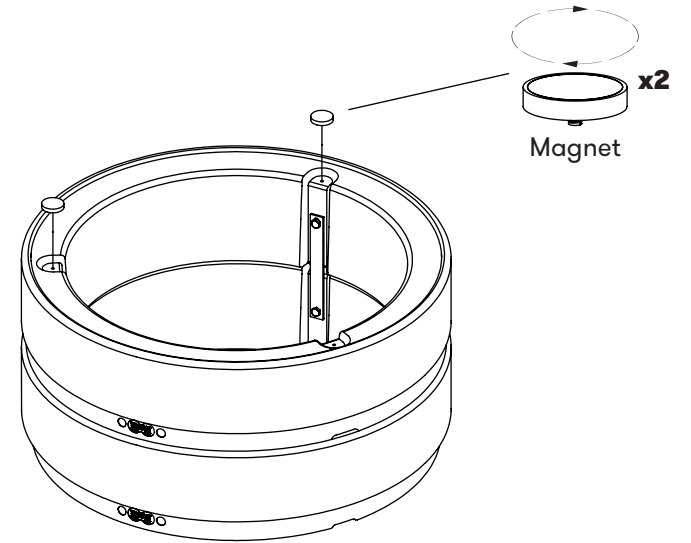

Measurements are excl top

out-sider a/s
Kigkurren 8A, Islands Brygge
DK-2300 Copenhagen S

info@out-sider.dk
outsiderfurniture.com

SOLO

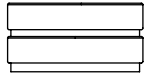

2. MAGNET PLATE ONLY FOR HPL TOP

MAGNETPLADE/MAGNETPLATTE/PLACA MAGNÉTICA/PLAQUE MAGNÉTIQUE

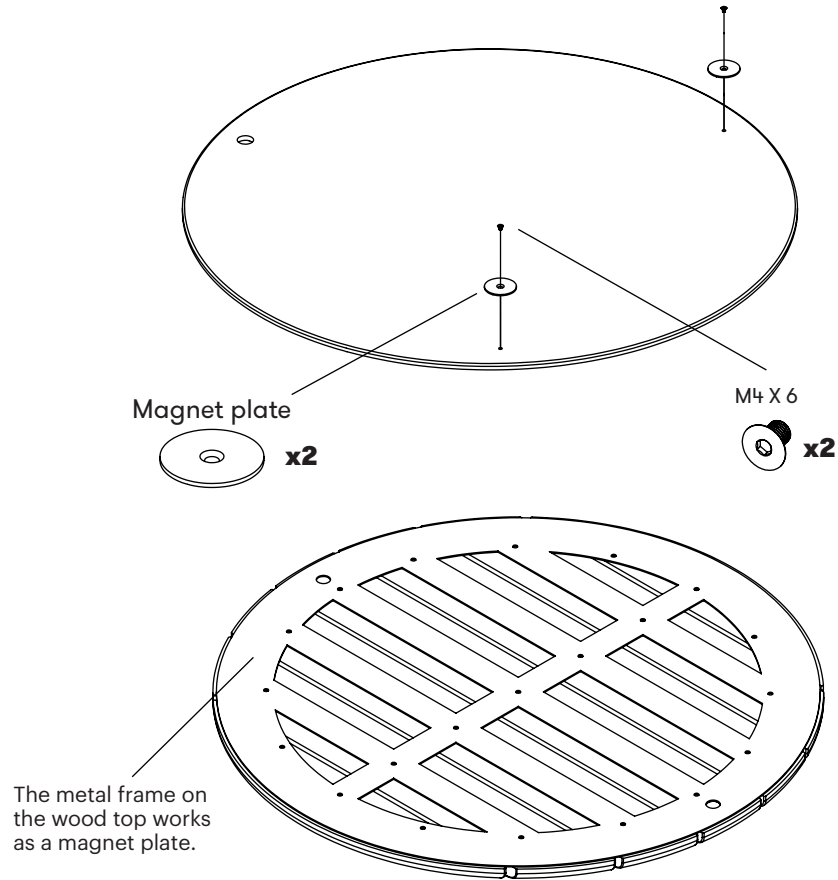

3. FITTING THE TOP

MONTERING AF TOPPEN/
MONTAGE DES DECKELS/
COLOCACIÓN DE LA TAPA/
INSTALLATION DU DESSUS

1. Align the magnet plates on the top with the magnets in the base.

2. Gently lower the top connecting the magnets.

Make sure the insert in the base align with the hole in the top

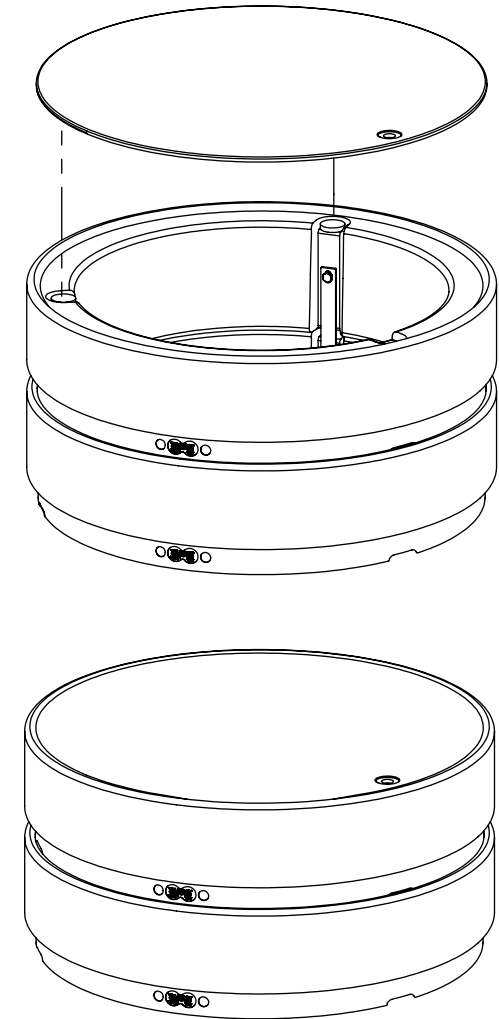

SOLO

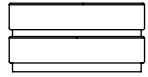
**4. TIGHTEN THE DISC**

STRAM DISKEN/SCHEIBE ANZIEHEN
APRIETE EL DISCO/SERREZ LE DISQUE

1. Place the disc in the top hole and tighten it with your hands.

Make sure to keep it vertical

2. Tighten the disc with the wrench spanner.

Do not over tighten

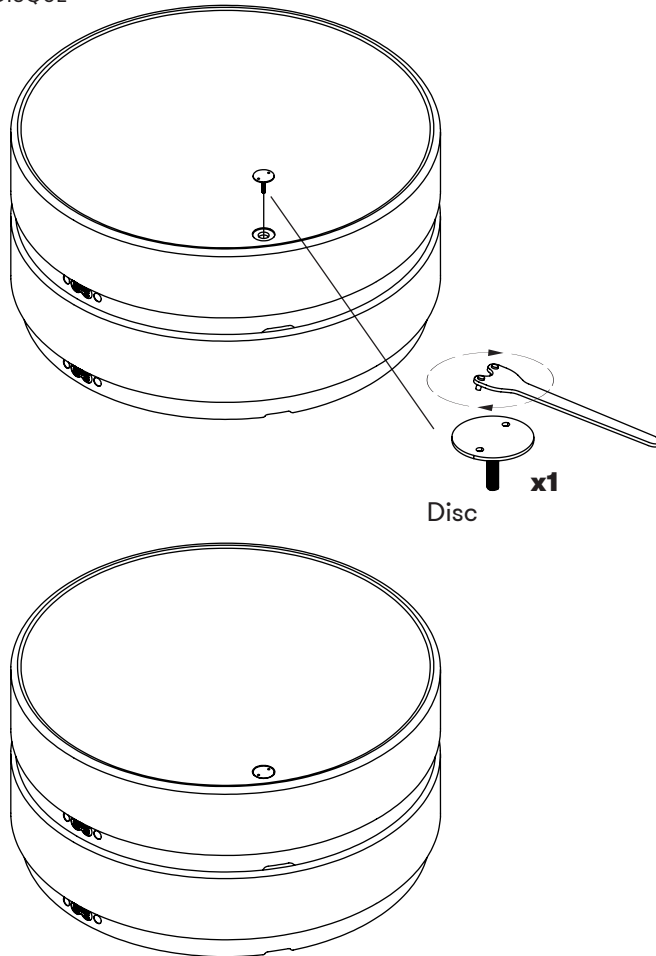

SOLO

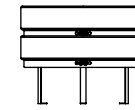
**B19 - GROUND FIXATION BRACKET**

NEDGRAVNING / BODENBEFESTIGUNG /
FIJACIÓN AL SUELO / FIXATION AU SOL

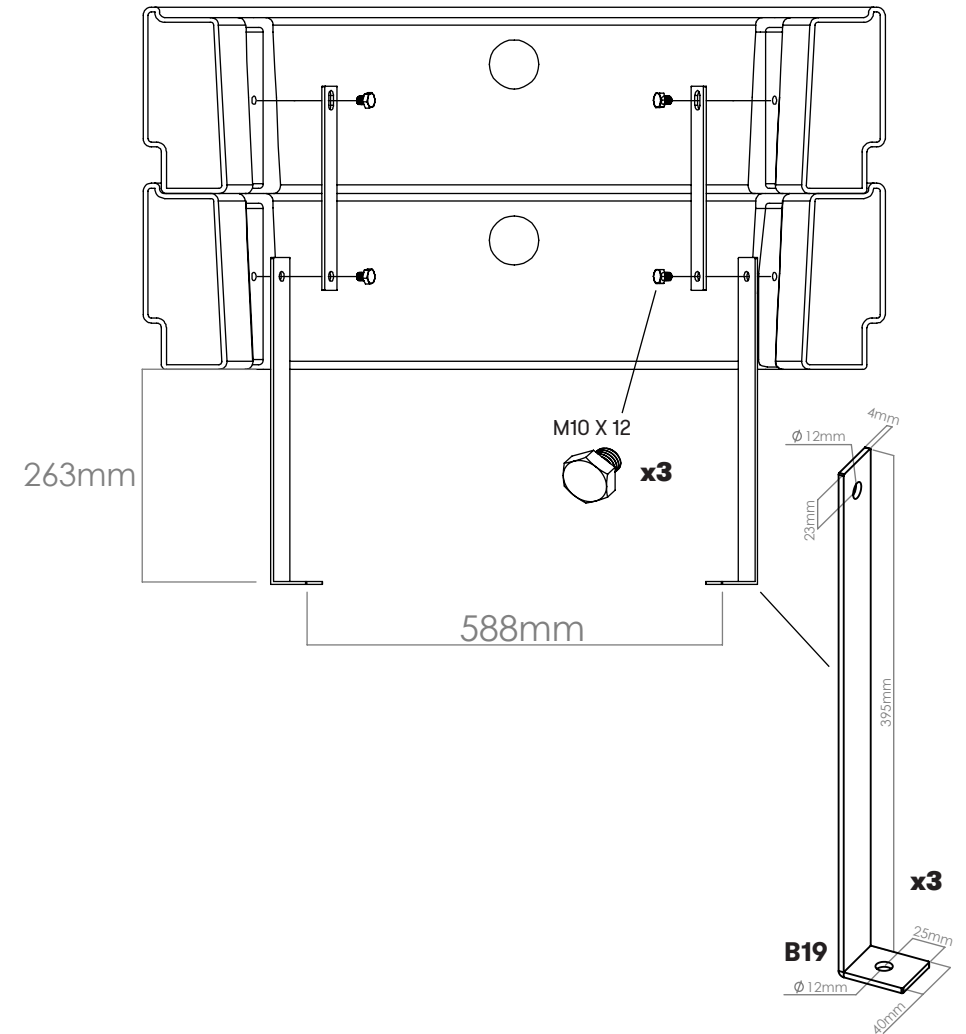

SOLO

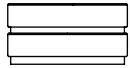
**B20 - SURFACE FIXATION**

OVERFLADEMONTERING/OBERFLÄCHENMONTAGE/
SUPERFICIE MONTANOSA/MONTAGE EN SAILLIE

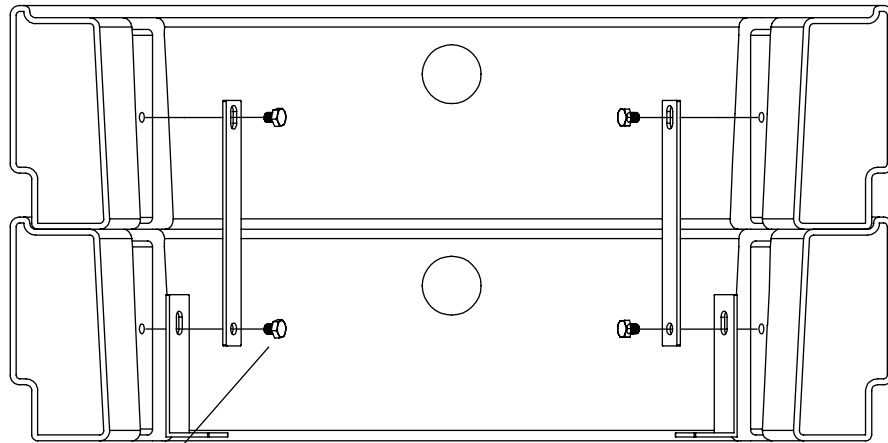

M10 X 12

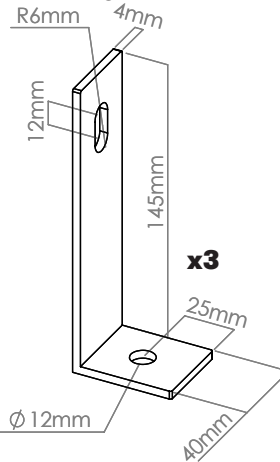

x3

B20

x3

SOLO

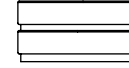
**B21 - PLANTER/SEAT & PLANTER TOP FIXATION**

MONTERING AF PLANTE TOP/BEFESTIGUNG DES PFLANZKÜBEL-
DECKELS/FIJACIÓN DE LA PARTE SUPERIOR DE LA JARDINERA/
FIXATION DU DESSUS DU BAC À PLANTES

1A. BRACKET FIXATION

FASTGØRELSE AF BESLAG/HALTERUNGSBEFESTIGUNG/FIJACIÓN DEL SOPORTE/FIXATION
DU SUPPORT

Place the top
up-side down and
fixate the B21 bracket
with the M4X10
with the washer
inbetween.

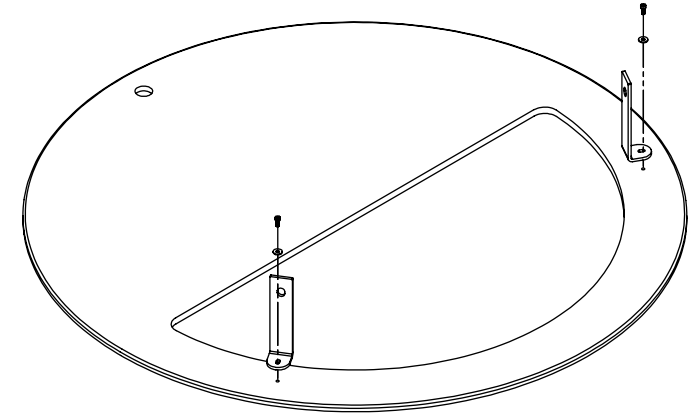

Make sure to protect
the top surface
when placing it
up-side down

M4 X 10



x2

A4 WASHER Ø4MM

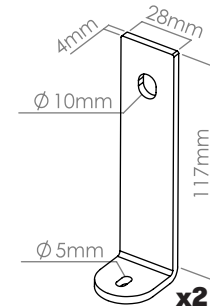

x2

B21

x2

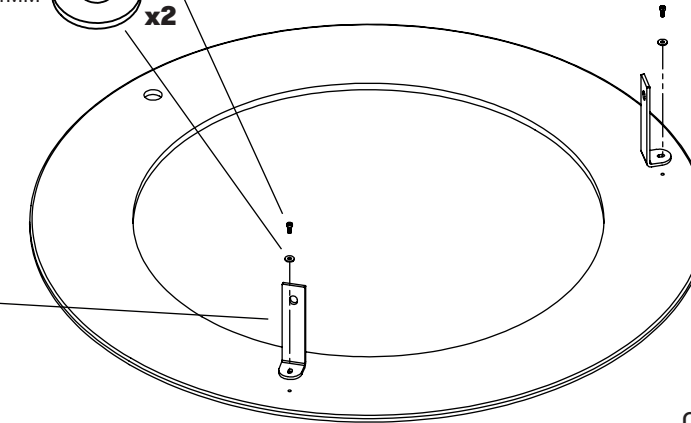

07

SOLO

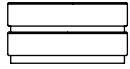
**1B. BRACKET FIXATION**

FASTGØRELSE AF BESLAG/HALTERUNGSBEFESTIGUNG/FIJACIÓN DEL SOPORTE/FIXATION
DU SUPPORT

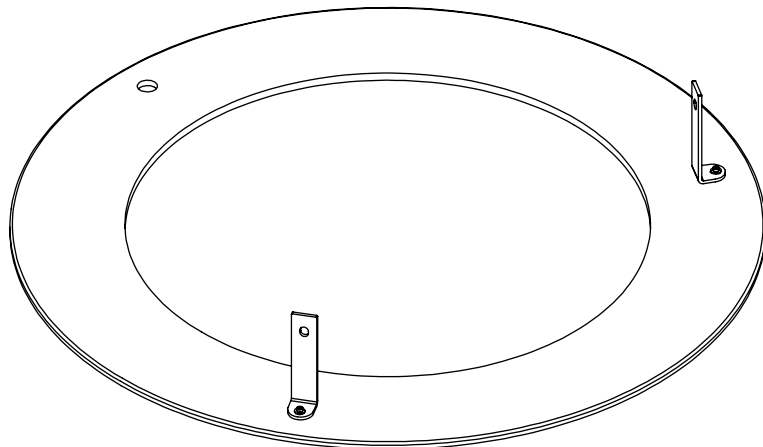
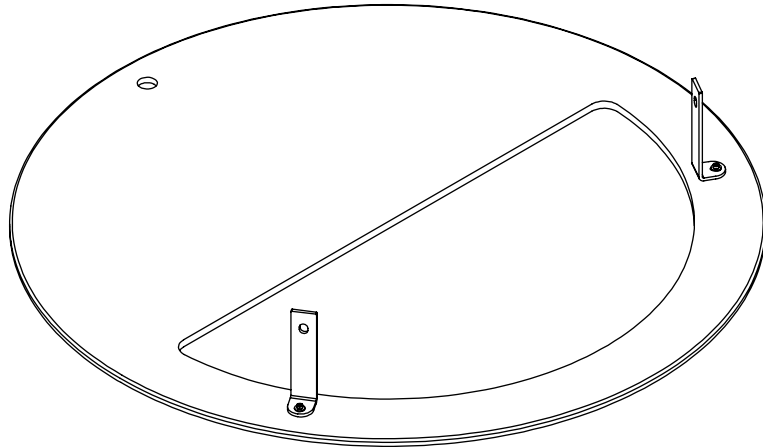
**2. PLACE THE TOP ON THE BASE**

PLACER TOPPEN PÅ BASEN/
SETZEN SIE DEN DECKEL AUF DEN BODEN/
COLOQUE LA TAPA SOBRE LA BASE/
PLACEZ LE DESSUS SUR LA BASE

The B21 bracket can
be fit on the inside
and the outside of the
connection brackets
B17 and B18.

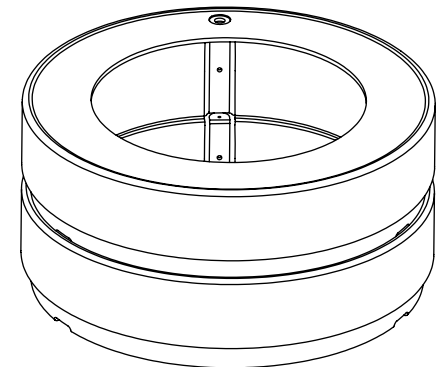
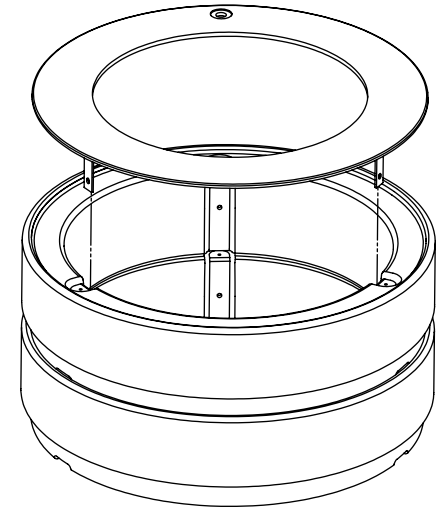

SOLO

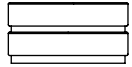

3. BASE & TOP FIXATION

FASTGØRELSE AF BASE & TOP/
BEFESTIGUNG VON BODEN UND
DECKEL/FIJACIÓND E LA BASE Y LA
PARTE SUPERIOR/FIXATION
DE LA BASE ET DU DESSUS

Fixate the B21 bracket
into the insert in the
base with the M10x12

Keep in mind if you are
using connection or/and
ground/surface brackets
to place them aligned so
the connection bracket
is fixated straight.

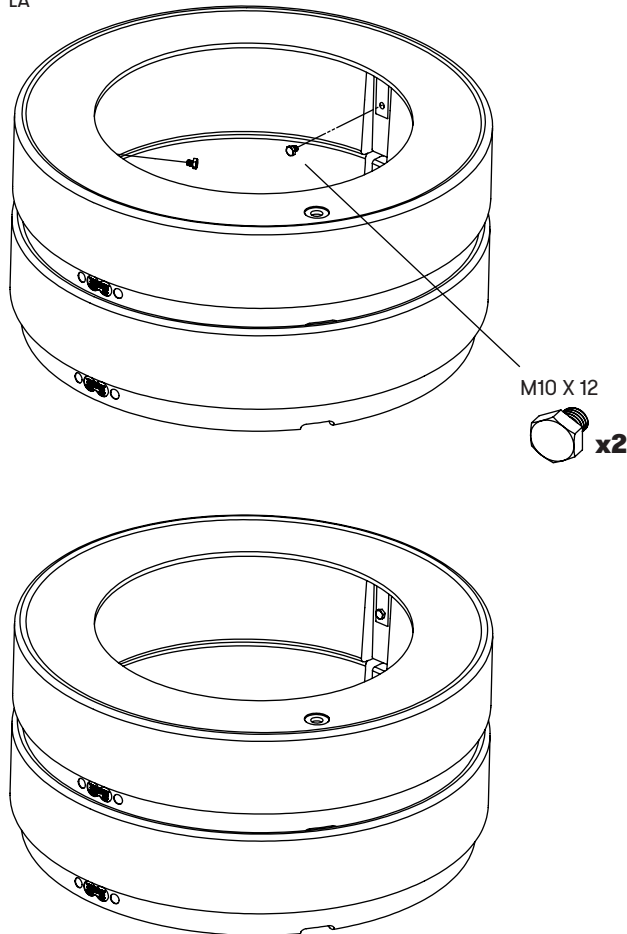

4. TIGHTEN THE DISC

STRAM DISKEN/SCHEIBE ANZIEHEN
APRIETE EL DISCO/SERREZ LE DISQUE

1. Place the disc in the
top hole and tighten it
with your hands.

Make sure to keep it
vertical

2. Tighten the disc with
the wrench spanner.

Do not over tighten

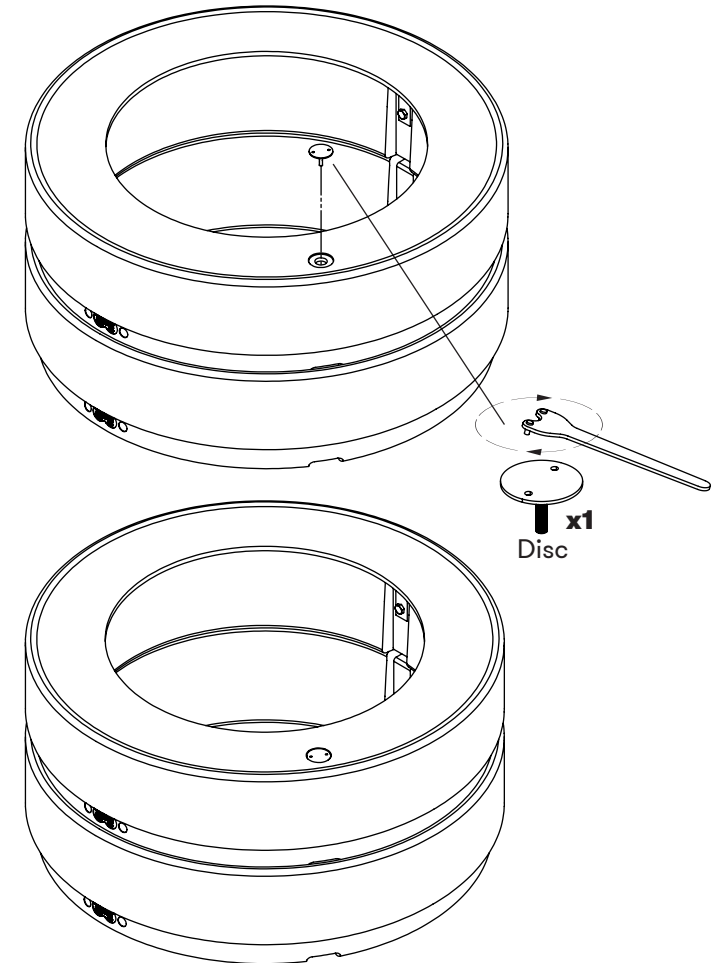

SHOCK ABSORBING SURFACE AND IMPACT AREA

Stødabsorberende overflade og stødområde/
 Stoßabsorbierende Oberfläche und Aufprallbereich/
 Superficie de absorción de impactos y área de impacto/
 Surface absorbant les chocs et zone d'impact

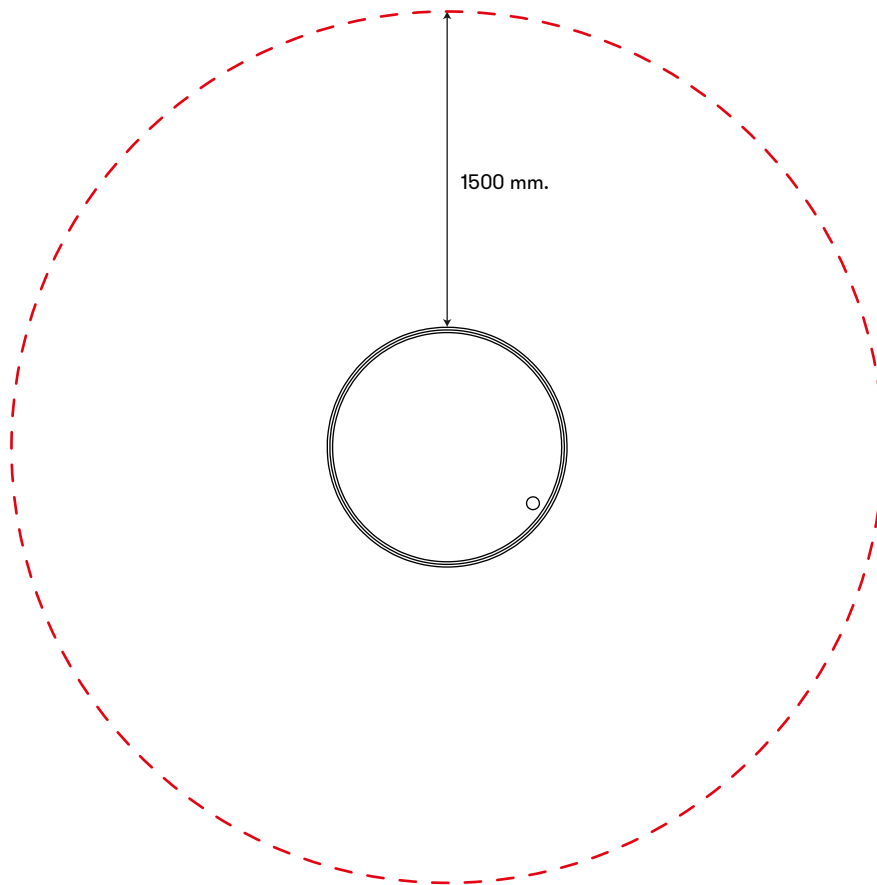

GB

Shock absorbing surface and the extension of impact area.
 In accordance with EN 1176-1:2023 we recommend an impact area of 1500mm
 (see dotted line)

For equipment with a fall height (FH) >600mm, the max. FH for the impact absorbing surface material shall be documented.

Note: The max. FH for the Circus Solo is 440mm.

DK

Stødabsorberende overflade og udvidelse af stødområdet.
 I overensstemmelse med EN 1176-1:2023 anbefaler vi et stødområde på 1500 mm
 (se stiple linje)

For udstyr med en faldhøjde (FH) >600mm, må max. FH for virkningen absorberende overflademateriale skal dokumenteres.

Bemærk: Den max. FH for Circus Solo er 440 mm.

DE

Stoßabsorbierende Oberfläche und Vergrößerung der Aufprallfläche.
 Gemäß EN 1176-1:2023 empfehlen wir eine Aufprallfläche von 1500 mm
 (siehe gestrichelte Linie)

Bei Geräten mit einer Fallhöhe (FH) >600mm beträgt die max. FH für die Wirkung absorbierendes Oberflächenmaterial ist zu dokumentieren.

Hinweis: Die max. FH für die Circus Solo beträgt 440 mm.

ES

Superficie amortiguadora y extensión del área de impacto.
 De acuerdo con EN 1176-1:2023 recomendamos un área de impacto de 1500 mm
 (ver línea de puntos)

Para equipos con una altura de caída (FH) >600 mm, el máximo. FH por el impacto Se documentará el material de la superficie absorbente.

Nota: El máx. FH para el Circus Solo es de 440 mm.

FR

Surface absorbant les chocs et extension de la zone d'impact.
 Conformément à la norme EN 1176-1:2023, nous recommandons une zone d'impact de 1500 mm (voir ligne pointillée)

Pour les équipements avec une hauteur de chute (FH) >600 mm, la hauteur max. FH pour l'impact
 Le matériau de surface absorbant doit être documenté.

Remarque : Le maximum. FH pour le Circus Solo est de 440 mm.